

OPERATING INSTRUCTIONS **Titan** HOIST

Models: Single phase: TITAN 501 and TITAN 651 hoist with Central Control box
 Three phase: TITAN 503 and TITAN 653 hoist with Central Control box
 Conform to EN 1808:2015 and Machine Directive 2006/42/EC



WARNING:

- All persons operating this equipment must read and completely understand this manual.
- All persons must be thoroughly trained in the use of the equipment, it's operational and safety features, and they must also be capable of carrying out the daily checklist.
- Only authorized and physically fit persons shall operate the equipment.
- Any operation in violation of these instructions is at the operator's own risk and may result in serious injuries.
- Keep this manual with the hoist at all times.
- Only use spare parts and steel wire rope from POWER CLIMBER,
- It is not allowed to put the machinery into service until the machinery into which it is incorporated or of which it is to be a component, has been found and declared to be in conformity with the provisions of Directive 2006/42/EC and with national implementing regulation.
- On platforms with only ONE hoist on ONE walk-through stirrup, an Overspeed safety device is compulsory, in addition to the standard slack rope safety device.

Manufacturer: Power Climber b.v.b.a, Satenrozen 7, B-2550 Kontich BELGIUM

Reference: 38740-E	Issue date: 2020 JUN 05	Revision: F	Page 1 of 17
---------------------------	-------------------------	-------------	--------------

TITAN HOIST

		TITAN Single Phase		TITAN Three Phase	
MODEL		TITAN 501	TITAN 651	TITAN 503	TITAN 653
Working Load Limit (W.L.L.)		5000N (500 kg)	6500N (650 kg)	5000N (500 kg)	6500N (650 kg)
Power Supply		230V / 50Hz + E		3 x 400V / 50Hz + N + E	
Amperage at W.L.L.	RUN	5.0 A	6.0 A	2.5 A	2.5 A
	START	20.0 A	24.0 A	7.5 A	7.5 A
Motor Power		0.75 kW	1.00 kW	0.75 kW	1.00 kW
Wire Rope Type		Type 8			
Hoisting Speed		ca. 8.5 m/min			
Noise Level		<80 dBA			
IP-Rate		IP 54			
Self-weight of hoist		45kg			



- Top limit switch
- Upper carrying handle
- Suspension rope
- Safety rope
- Slack rope lever
- Electrical Box and Motherboard
- Electric supply cable



- 'No Power' emergency descent
- Nameplate (serial no.)
- Electric motor
- Lower carrying handle

Reference: 38740-E	Issue date: 2020 JUN 05	Revision: F	Page 2 of 17
---------------------------	-------------------------	-------------	--------------

TITAN HOIST

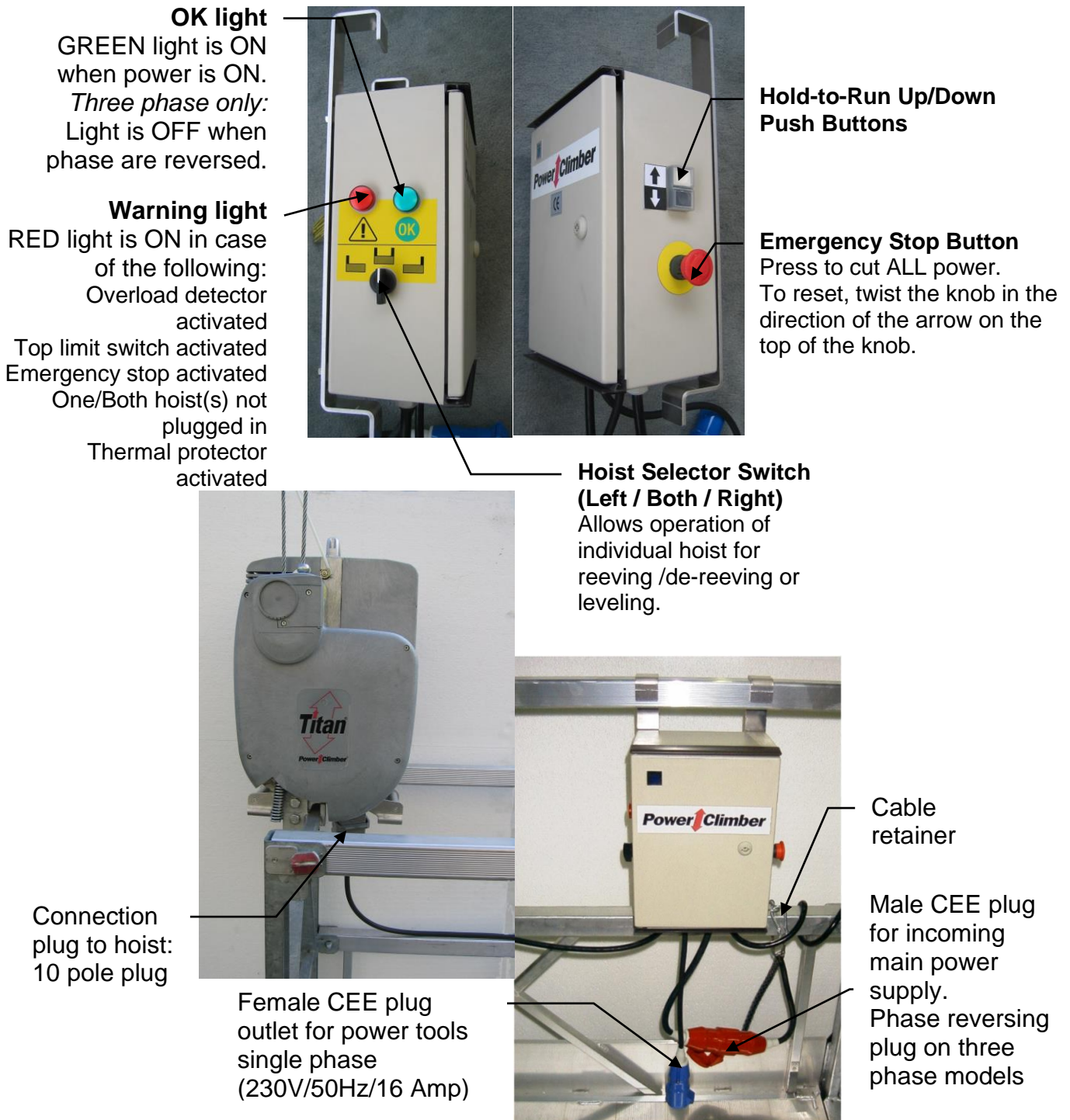

The TITAN hoist is a self-reeving traction hoist, powered by an electric motor. The hoists and the central control box (CCB) are mounted on Temporary Suspended Platforms (TSP) and suspended with steel wire ropes from a suspension system. The strength of the platform and the suspension system used in combination with the hoists must be in relation to the Working Load Limit (WLL) of the hoist.

Reference: 38740-E	Issue date: 2020 JUN 05	Revision: F	Page 3 of 17
---------------------------	-------------------------	-------------	--------------

TITAN INSTALLATION

A. Install CCB and connect Power Supply

1. Install CCB on the rear platform guardrail away from the working area.
2. Connect the control cables from the CCB to each TITAN hoist.
3. Connect the main power supply cable to the male plug on the CCB, and secure it to the mid-rail of the platform using the cable retainer.

Note: Both hoists have to be connected to the CCB for either hoist to operate.

B. Reeve the suspension ropes in the TITAN hoist

At roof level, uncoil the suspension ropes and lay them on the roof surface. Attach the suspension ropes to the suspension system with the safety hooks fitted to the ropes and lower the ropes to the ground. Verify that the rope is long enough.

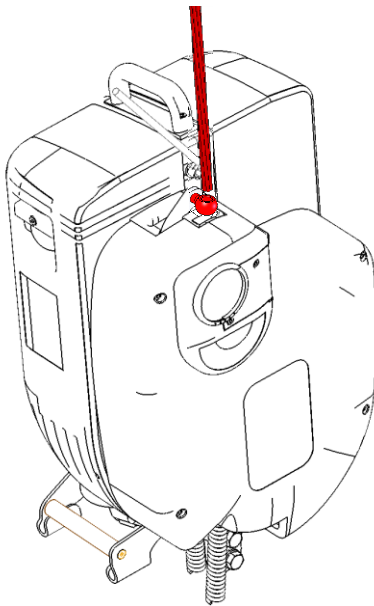

1. Push back the slack rope lever and insert the suspension rope through the eye of the slack rope lever and into the hoist until it stops.
2. Push the 'up' button on the CCB and the steel wire rope passes through the hoist automatically. The end of the rope will come out from the bottom of the hoist. Make sure the outlet is free and the wire rope can come out.

Tip: If there is any difficulty reeving the suspension rope it helps to put a small bend in the end of the rope before feeding it into the hoist.

C. Attach the TITAN hoist to the stirrup

1. Lift the TITAN up from the ground by pushing the 'up' button on the CCB. Line up the holes in the stirrup bar with the holes in the stirrup.
2. Attach the TITAN hoist to the stirrup of the platform with M12 bolts and self-locking nuts. Make sure that the TITAN hoist is mounted with the main hoist label towards the inside of the platform.

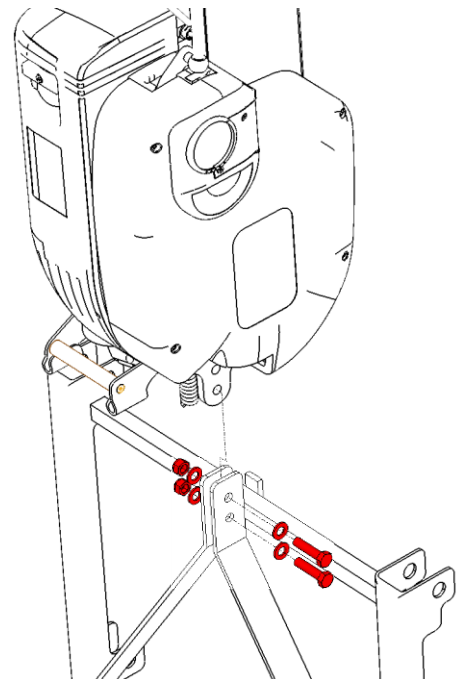

TITAN INSTALLATION

D. Reeve the safety rope in the TITAN hoist

At roof level, uncoil the safety ropes and lay them on the roof surface. Attach the safety ropes to the suspension system with the safety hooks fitted to the ropes and lower the ropes to the ground. Verify that the rope is long enough.

Push back the slack rope lever (or tension the suspension rope) to open the jaws of the slack rope safety device and push the safety rope through the slack rope compartment. Take out all slack by putting a weight on the tail end of the safety rope.

Tip: Separately reeving the safety rope and the suspension rope, will avoid getting them twisted together.

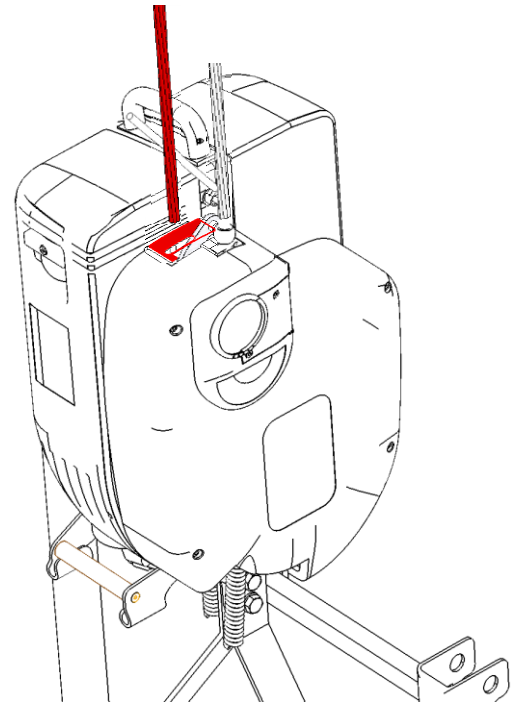

E. Carry out Daily Checklist

Carry out the Daily Checklist prior to your first ascent to install the top limit switch striker plates. Always check the suspension system for stability and safety before launching the platform.

F. Install Top Limit Switch Striker Plates

The striker plate activates the top limit switch and must be clamped on the safety wire at a distance of min. 20cm from the Talurit clamp.

IMPORTANT	Clamp the striker plate to the safety rope ONLY so that the suspension rope passes freely through the slot in the plate.
------------------	---

REMOVING the steel wire rope from the TITAN hoist

Tip: Remove the safety rope first and keep the suspension rope taut, so that the slack rope safety device stays open and allows easy passage of the safety rope.

Safety rope	Manually pull the safety rope out of the slack rope safety device by hand.
Suspension rope	Push the 'down' button on the CCB until the suspension rope no longer comes out of the top of the hoist and pull out the remainder of the rope by hand. <i>Tip: push up on the slack rope lever for easy removal of the suspension rope.</i>

After work is over check that:

- The platform is cleared of tools and equipment.
- All power has been switched off.
- Equipment has been secured where it will not be accessible to be tampered with.

Reference: 38740-E	Issue date: 2020 JUN 05	Revision: F	Page 5 of 17
---------------------------	-------------------------	-------------	--------------

TITAN MAINTENANCE

ROUTINE MAINTENANCE:

at least every 3 months under normal use, or 50hrs, whichever comes first.

Note: No specialised training is required to perform this basic maintenance.

- 1) Check all plugs socket connections of the hoist and central control box for any signs of water penetration.
- 2) Make a general inspection of hoist for excessive wear and damage.
- 3) Remove main cover and inspect mechanism for any signs of excessive dirt and corrosion. If required, blow out with air or rinse with water.
- 4) Check that traction roller rotates when reeving / de-reeving the steel wire rope through the hoist.
- 5) Check the slack rope safety device for excessive dirt and corrosion. If required, blow out with air or rinse with water. Check that the slack rope lever can move smoothly up and down. If necessary, lubricate with a dry wax-based spray lubricant.
- 6) Replace main cover.
- 7) Carry out the Daily Check List before using the platform.
- 8) Write a maintenance record indicating:
 - Any discrepancies noted and action taken.
 - Hour meter (optional) reading of the hoist.

ANNUAL MAINTENANCE: to be carried out by an authorized service centre

- 1) Completely strip the hoist, clean and inspect all parts for wear and damage. Replace worn parts when necessary.
- 2) Clean, lubricate and re-assemble the hoist. Particular attention must be given to the slack rope safety device.
- 3) Place the hoist on a test rig and test that it can lift the rated Working Load Limit.
- 4) Check all plugs socket connections of the hoist and central control box for any signs of water penetration.
- 5) Reinstall the hoist and control box back on the platform and carry out the Daily Check List.
- 6) Write a maintenance record indicating:
 - Repairs carried out and/or parts replaced.
 - Hour meter (optional) reading of the hoist.

Special conditions:

The frequency of inspection and maintenance also depends upon the environmental and working conditions:

- When working with abrasive, adhesive or corrosive materials (epoxy, paint, cement, sand blasting, acids, salt water, spraying), the hoist should be protected with a suitable cover and the daily checklist carried out at least once a day.
- Always exercise caution regarding grounding, arcing and insulation, whenever welding or using electrical equipment.

Reference: **38740-E**

Issue date: 2020 JUN 05

Revision: F

Page 6 of 17

TITAN TROUBLESHOOTING

Problem	Probable cause	Solution
Hoists do not work when pressing the 'up/down' push button. GREEN 'OK' light OFF	No Mains power	Check power that power plug is properly connected or go down using the emergency manual descent
	<i>Three phase hoists only:</i> Phases are reversed	Use screwdriver to reverse phases on the phase reversal power plug of the CCB.
Hoists do not work when pressing the 'up/down' push button. RED warning light ON	Emergency stop button has been depressed	Release emergency stop button
	Both hoists are not connected to the CCB	Check that both hoists are correctly plugged in the CCB
During reeving, the hoist works in the 'up' direction, but the suspension rope does not reeve through	Steel wire rope is not entering the hoist properly	Remove steel wire rope and repeat reeving procedure (see Tip)
Hoists work for just a moment in the "up" direction and then stop. RED warning light ON	The platform is overloaded	Remove excessive load to automatically reset overload
The hoists do not work in the up direction RED warning light ON	Top limit switch has been activated	Check for obstruction (e.g. hitting the striker plate)
Hoist hums, starts slowly or is sluggish, or fails to lift the loaded platform.	Serious voltage drop	Check the power supply and the specifications of the power supply cable
	<i>Single phase hoist only:</i> Start capacitor is defective	Hoist to be checked by an approved service centre
	Service brake failure	Hoist to be checked by an approved service centre
The hoists work for a long time and then stop. The electric motors are hot. RED warning light ON	The thermal protection has been activated	Let the motors cool down to reset automatically. Tip: The 'no power' descent will still operate when the overheating protector is tripped.
The hoist turns both in the 'up' and 'down' direction, but the platform does not come down	The slack rope safety device is activated, and platform is tilted or has come to rest on an obstruction)	Use the hoist selector switch to bring platform to the horizontal level or go up to come off the obstruction.
Slack rope lever does not pivot properly	Slack rope mechanism is contaminated by grit or corrosion	Clean and lubricate slack rope safety device
IF PROBLEM PERSISTS, CONTACT YOUR LOCAL SERVICE REPRESENTATIVE.		

TITAN SAFETY DEVICES

1. Automatic slack rope safety device:

The automatic slack rope safety device locks mechanically onto the safety rope if:

- a) the suspension rope loses tension or breaks.
- b) the platform gets out of level by max. 14 degrees. The slack rope safety device on the lower hoist will lock mechanically onto the safety rope.

This is in addition to the automatic levelling system and protects against a slow creep down of the hoist.

2. Overload detection device:

The overload detection device of each hoist is factory set to stop the 'up' direction of travel if the Working Load Limit (WLL) of the hoist is exceeded by 25%.

The RED warning light on the central control box will come ON in case of overload.

The overload detection devices of both hoists are connected in series. If one overload detection device is triggered, then the up movement of both hoists is halted.

To release the overload detection device, remove the excessive load.

Tip: *In addition to removing the excessive load, it may be required to remove part of the normal load in order to reset the overload detection device. Once the overload detection device is reset, the platform can once again be loaded with the full normal load.*

3. 'No-Power' descent

In the event of a power failure the platform can be lowered at a controlled speed (approx. 6 m/min.), by pulling the 'No-Power' descent lever on the electro-magnetic service brake.

Warning: *Never use the emergency manual descent when normal powered movement is possible.*

4. Top limit switch

The top limit switch cuts the up movement when it is activated by the striker plate, which is clamped onto the safety rope at the top of travel.

When the top limit switch is triggered, the platform can be driven down but not up.

The top limit switches of both hoists are connected in series. If one top limit switch is activated, then the 'up' movement of both hoists is halted.

5. Phase Protector (for three phase hoist ONLY)

All three phase central control boxes are fitted with a phase protector, which cuts power supply if phases are reversed. When the phases are correctly connected, the GREEN 'OK' indicator light on the outside of the CBB, AND the GREEN indicator light on the phase protector (only visible when CBB is opened) are ON and the hoists will operate. If indicator lights are OFF, use a screwdriver to reverse the phases in the phase reversal power plug of the CCB.

WARNING: DO NOT change any connections in the central control box.

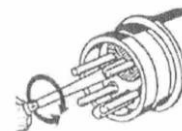

Reference: 38740-E	Issue date: 2020 JUN 05	Revision: F	Page 8 of 17
---------------------------	-------------------------	-------------	--------------

TITAN SAFETY DEVICES

6. Automatic Levelling System

The central control box is fitted with an automatic levelling system that allows the platform to maintain a stable horizontal position. An out of level condition can occur when one of the hoists is working faster than the other, or if the load in the platform is not evenly distributed.

When the platform is in motion, the automatic levelling system stops the hoist that is going too fast and allows the other hoist to catch up. When both hoists are level again, the levelling system is deactivated and both hoists will function simultaneously.

The automatic levelling system is activated when the platform is out of level by 3-6°.

The Automatic Levelling System can be tested by using the hoist selector switch to create and out of level condition. Once the platform is out of level, check that the hoist that is too high no longer works in the 'up' direction and the hoist that is too low no longer works in 'down' direction.

7. Overheating protection for hoist electric motor

The hoist motors are fitted with a thermal contact, which cuts power to the motors in case of overheating.

When the overheating protection is activated, the 'up' movement is halted.

If a hoist motor has overheated, allow it to cool down to continue.

The overheating protectors of both hoists are connected in series. If one overheating protector is triggered, then the 'up' movement of both hoists is halted.

8. Overspeed Safety device (OPTIONAL)

The overspeed safety device locks onto the suspension rope when the suspension rope passes through the hoist (descent speed) at more than 15 m/min. The overspeed safety device can also be triggered manually by pressing the manual release button.

To reset the overspeed safety device, first drive the hoist up a few centimetres and then turn the reset knob clockwise in the direction of the arrow.

9. Use of Handwheel to reset safety device in case of power failure

If the slack rope safety device or overspeed safety device (*optional*) has been activated and there is no power to the platform, it will be necessary to wind the hoist up a few centimetres manually, to be able to reset the safety device.

1. Pull out main power plug to cut off power supply.
2. Remove plastic plug in the motor cover to expose shaft for the handwheel.
3. Remove the hand wheel from its storage position and insert shaft into hub.
4. Wind the hoist in the up-direction counter-clockwise ½ turn at the same time as you pull up on the brake lever to open the brake.
5. Release brake lever and repeat.

TIP: *Grab the hand wheel firmly while opening the brake to prevent it from turning and going back down.*

6. The overspeed safety device (optional) must be reset manually. The slack rope safety device resets automatically.
7. Put plastic plug back on and return hand wheel to its storage position after use!
8. Plug in main power plug and resume.

Reference: 38740-E	Issue date: 2020 JUN 05	Revision: F	Page 9 of 17
---------------------------	-------------------------	-------------	--------------

TITAN STEEL WIRE ROPE

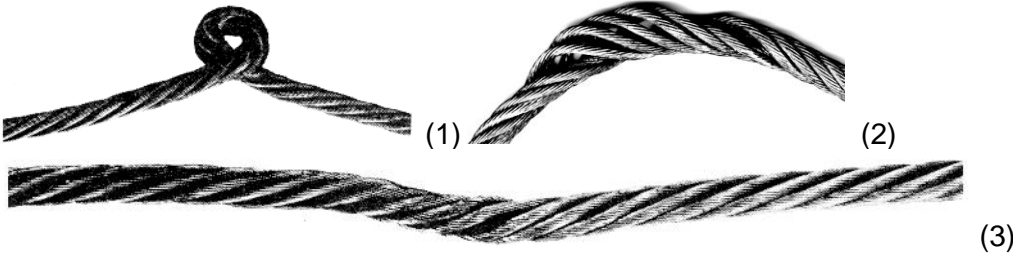
ONLY USE POWER CLIMBER RECOMMENDED STEEL WIRE ROPES	
Type	Greenflex
Diameter	8.4 mm
For use with hoist model	All models of TITAN hoist
Construction	5 x 26 WSR (Warrington Seale Compacted) + HDPP (High Density Polypropylene) core
Structure	Right Hand Cross Lay - Light Preformed
Tolerance	(+0/-0.2mm)
Tensile strength of wires	1960 N/mm ²
Minimum Breaking Load (actual)	52.3 kN
Minimum Breaking Load (calculated)	66.0 kN
Weight	0.255 kg/m
Treatment	Galvanized
Identification mark	Green strand
<ul style="list-style-type: none"> The end of the steel wire rope should be brazed to form a 'bullet' end with a maximum length of 10mm, without loose or broken wires. Use protective gloves to manipulate the Steel Wire Ropes. If Steel Wire Ropes are too long, carefully wind any extra cable into a loop (or onto the wire holders) and tie up, leaving the coil suspended just clear of the ground. 	
<p style="text-align: right;">10mm</p> 	
<p>WARNING:</p> <p>Steel Wires Ropes must be replaced in any of the following conditions:</p> <ul style="list-style-type: none"> More than 10 wires are broken on a length of 25cm Excessive corrosion Damage due to heat Reduction of the nominal diameter by more than 10% Kinking (1), crushing (2), bird caging (3) or any other distortion of the wire rope structure. 	
	

MODULO PLATFORM and SAFEFIX SYSTEM

The modular design of the MODULO® suspended platform allows you to modify the configuration of the standard components to obtain the size platform required. These components are secured together by using the patented SafeFix pin system, a one step “insert and snap” method to assemble MODULO® platform components. The slotted pin is fixed in place by a spring mounted on the stirrup or U-frame.

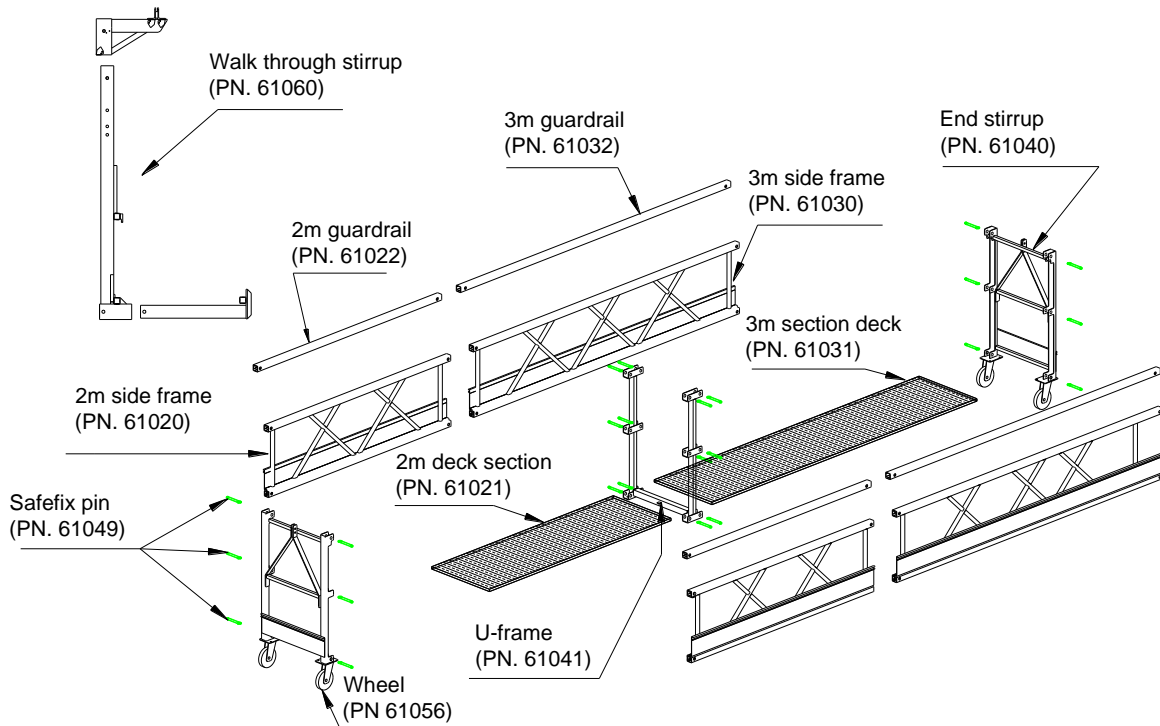

Insertion of the SafeFix pin

- Line the pin up with the hole, so that the slot at the base of the pin is horizontal.
- Push the pin in from outside until the spring clicks in the grooves on the shaft of the pin. If required, rotate the pin till the slot is horizontal and the springs are in place.
- Make sure the pin is secured.

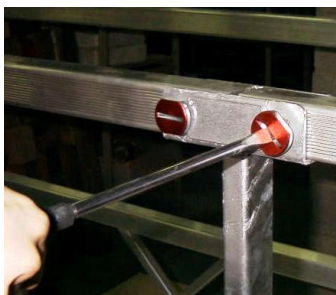

Removal of the SafeFix pin

- Rotate the pin ¼ turn till the slot is vertical (and the springs are no longer in the grooves) and pull the pin out.

Note: The pin can be positioned with the use of a hammer and a screwdriver.

ATTENTION:

Springs have to be replaced when they no longer exert pressure on the grooves of the pin shaft.

Reference: **38740-E**

Issue date: 2020 JUN 05

Revision: F

Page 11 of 17

ASSEMBLY: MODULO with End-Stirrup



1a

1. The assembly process begins with the centre section and continues towards each end of the platform. Start with a one-piece U-frame and install two side frames onto the U-frames and secure each side-frame in position with 2 SafeFix pins.

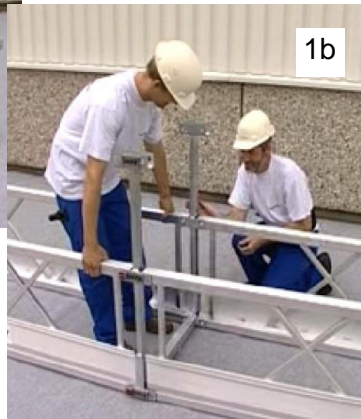

1b

2. Continue the assembly with U-frames and side frames to obtain the required platform length and finish assembly by installing the one-piece end-stirrup



2



3

3. Insert the aluminium floor (flat side up).

4. Check that all 4 retaining springs are in place.

NOTE:

To remove floor, push on the spring and lift floor at the same time.

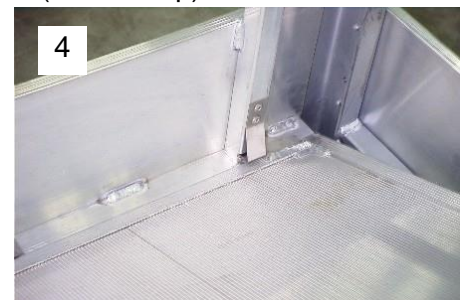

4

5. Install the guardrails, inserting a SafeFix pin in each end.



5



6

6. Install the wall rollers that can be located anywhere along the length of the side frame as required.

Use minimum 2 wall rollers and put them wide apart.

WARNING:

- Visually inspect all SafeFix pin connections before using the platform
- Always install the guardrail before using the platform
- Never stand on the guardrail or mid-rail while platform is in use
- A platform with end-stirrups should not be configured with more than 3 U-frames between suspension points

ASSEMBLY: MODULO with Walk Through Stirrup

Assemble the Modulo platform to the required length with standard end-stirrups. These end stirrups will function as end guardrails

1. Hang the mast over the mid-rail. Make sure that position is in line with the suspension points; otherwise the slack rope safety mechanism will not work properly.

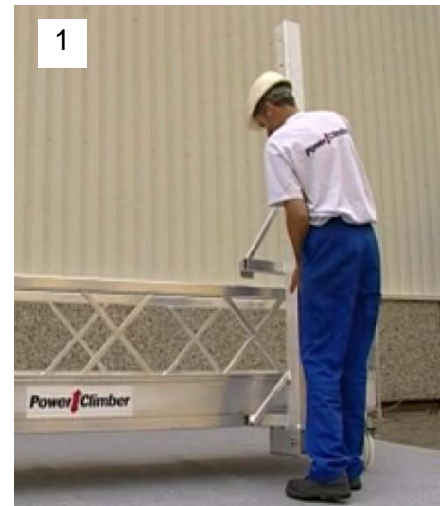

2. Insert the lower part into the mast and lock with the SafeFix pin, making sure that the front tab is correctly fitted into the channel on the front side-frame.

3. Insert the upper horizontal arm and set the position to the required height. Lock with a second SafeFix pin.



4. Mount the hoist (see hoist installation) and insert both steel wire ropes in the diverter guides.



ATTENTION: When mounting the hoist, pay particular attention to the orientation of the hoist.

- Suspend minimum 6 kg on the suspension rope.
- Suspend minimum 12 kg on the safety rope.

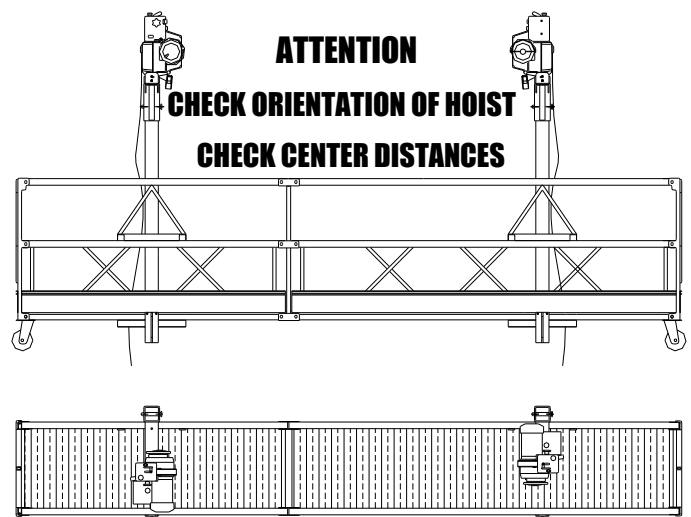

WARNING: Visually inspect all SafeFix pin connections before using the platform
On platforms with only 1 walk-through stirrup, an Overspeed safety device is compulsory.

MODULO LOAD TABLE

ATTENTION: LOAD TABLES FOR EVENLY DISTRIBUTED LOAD ONLY

Platform with end stirrups				Titan 500 kg		Titan 650 kg	
Length	Configuration	Max. load per meter	Self-weight (platform only)	Rated load	Max. no. of persons	Rated load	Max. no. of persons
(m)		(kg/m)	(kg)	(kg)		(kg)	
2	2	186	95	360	2	360	2
3	3	186	110	540	3	540	3
4	2+2	186	150	700	4	720	4
5	2+3	186	165	680	5	920	5
6	3+3	186	185	660	6	960	6
7	2+3+2	186	220	630	6	930	7
8	3+2+3	186	240	610	6	910	8
9	3+3+3	150	255	590	6	890	9
10	3+2+2+3	120	295	550	5	850	9
11	3+3+2+3	120	310	540	5	780	8
12	3+3+3+3	120	330	520	5	680	7

Platform with walk through stirrups				Titan 500 kg				Titan 650 kg			
Length	Configuration	Min. Rope Centre	Self-weight (platform only)	Max. rated load	Max. no. of persons	Max. load per meter	Cantilever	Max. rated load	Max. no. of persons	Max. load per meter	Cantilever
(m)			(kg)	(kg)		(kg)	(m)	(kg)		(kg)	(m)
1.5	2	n.a.	150	360	2	186	1.0	360	2	186	1.0
3	3	2	165	540	3	186	0.5	540	3	186	0.5
4	2+2	2	205	660	4	160	0.5	720	4	186	0.5
5	2+3	3	225	640	5	130	0.5	900	5	186	0.5
6	3+3	4	240	320	3	120	0.5	920	6	168	0.5
7	2+3+2	5	280	310	2	120	1.0	880	7	120	1.0
8	3+2+3	6	295	300	3	120	1.0	560	6	120	1.0
9	3+3+3	7	310	280	3	120	1.0	520	5	120	1.0
10	3+2+2+3	8	350	260	2	120	1.0	460	4	120	1.0
11	3+3+2+3	9	370	250	2	120	1.0	440	4	120	1.0
12	3+3+3+3	9	385	240	2	120	1.5	400	4	120	1.5
13	3+2+2+3+3	10	425	220	1	120	1.5	370	3	120	1.5
14	3+3+2+3+3	10	440	210	1	120	2.0	360	3	120	2.0
15	3+3+3+3+3	11	455	200	1	120	2.0	350	3	120	2.0
16	3+3+2+2+3+3	12	495	180	1	120	2.0	330	3	120	2.0

Note: Other numbers of cantilever and loadings upon request

Reference: 38740-E	Issue date: 2020 JUN 05	Revision: F	Page 14 of 17
---------------------------	-------------------------	-------------	---------------

PRECAUTIONS

See European Standard EN1808 for details on Applications that are excluded from the EN1808 and other relevant exclusions.

TSP= Temporary Suspended Platform

1. Power Supply to the TSP must be fitted with

- a) Main switch
- b) Residual current device (or earth leakage circuit breaker) of 30 mA
- c) Overcurrent protective device (automatic fuse Type C)

Note: check that the specifications of the electrical supply cable match the power requirement of the platform and will avoid a voltage drop due to cable length.

2. Weather conditions

- Temperature range: -10°C and +55° C
Humidity range: 30 % - 95 %
Contaminants: Degree of protection IP 54
Max. wind speed: 12.5m/s (see note)

Note: For TSP with a lifting height over 40m and intended to be used on locations exposed to wind speeds over 14 m/s, an adequate restraint system shall be provided.

3. Precautions prior to use

- a) Before using the equipment, operators must carry out the daily checks and make sure that the equipment is in perfect working condition.
- b) Before use, modular TSP equipment must be checked to prevent mixing of inappropriate components.
- c) Before use, check that sufficient space is available for operating the TSP.
- d) Before using the equipment the suspension system must be checked to ensure the stability of the TSP at all times.
- e) In case the area below the TSP is open to the public, preventive measures have to be taken to safeguard the people below (e.g. barriers, roof protected walkways, etc.).
- f) All hazards related to the platform encountering obstructions are not completely covered by the TSP's safety devices. The operator shall check for obstructions along the travel of the platform.
- g) Overload detection device may not protect TSP platforms in all configurations. The operator shall check that the loading of the platform is in accordance with the rated load indicated on the nameplate.
- h) An area must be available to allow operators to get on and off the platform.

4. Precautions during use

- a) The operators must stop working with the equipment and notify the supervisor if faults, damage to the equipment or other circumstances may jeopardize safety.
- b) A suitable communication between the operator and the supervisor is recommended.

5. Suspension System

- a) The platform can be suspended on different types of suspension systems such as roof beams (with counterweights), parapet clamps, davits, fixed suspension points, custom made suspension systems, roof rigs made from tubular scaffolding etc.
- b) Roof systems to be calculated for a max. load of W.L.L. x 3 (Maximum allowable stresses below yield.)
- c) Check that roof beams are properly counterweighted (if applicable).
- d) Ensure that the suspension rig is directly above the platform prior to installation.

Reference: 38740-E	Issue date: 2020 JUN 05	Revision: F	Page 15 of 17
---------------------------	-------------------------	-------------	---------------

TITAN DAILY CHECKLIST

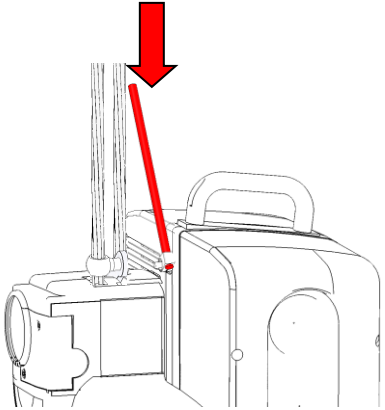
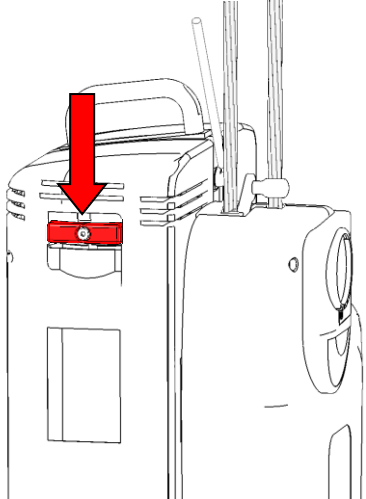
TESTS MUST BE CARRIED OUT EVERY TIME BEFORE USING THE PLATFORM	
1	Visually inspect the platform for damaged, loose or missing parts.
2	Check the suspension system for stability before launching the platform. Check that all counterweights are in place and secured. Check that all steel wire ropes are hooked on properly to the suspension system
3	Check that the GREEN ' OK ' indicator light on the CCB is ON .
4	Check that the ' Up/Down ' push buttons and the hoist selector switch are functioning.
5	Push emergency stop button and check that the platform cannot go up or down. (turn button in direction of arrow to reset)
6	<p>Push down on the Top Limit Switch and check that it cuts the 'up' direction, but that platform can be driven in the 'down' direction. Repeat procedure for other hoist.</p> 
7	<p>Push the UP direction followed by activating the overload switch manually. The UP and DOWN direction must be cut off as long as the overload switch is activated.</p> <p>This test must be performed when the cover of the motherboard was removed from the hoist.</p>
↑ Drive the platform 1-2 meters off the ground to continue the tests ↑	
8	<p>a) ON ONE HOIST ONLY, Pull on the 'No Power' emergency descent lever and check that the hoist can be lowered at a controlled speed.</p> <p>b) Continue releasing the service brake until the slack rope safety device is activated (about 14 degrees) and keeps the platform from tilting further.</p> <p>c) Repeat the procedure by manually lowering the other end of the platform.</p> 

TITAN DAILY CHECKLIST

9	Run the platform to the top and during travel inspect the steel wire ropes for kinks, broken wires or other damage. Inspect the trailing electrical supply cable for damage. At the top of travel, check that the top limit switch striker plates are correctly fitted and also that the top limit switches are operated by the striker plates.
DO NOT USE EQUIPMENT THAT IS NOT OPERATING PROPERLY	
NEVER OVERRIDE LIMIT SWITCHES AND SAFETY DEVICES	

Reference: 38740-E	Issue date: 2020 JUN 05	Revision: F	Page 17 of 17
---------------------------	-------------------------	-------------	---------------