

Operation and Installation instructions

BAP360 Platform **Blade Access Platform – UltraMax layout**

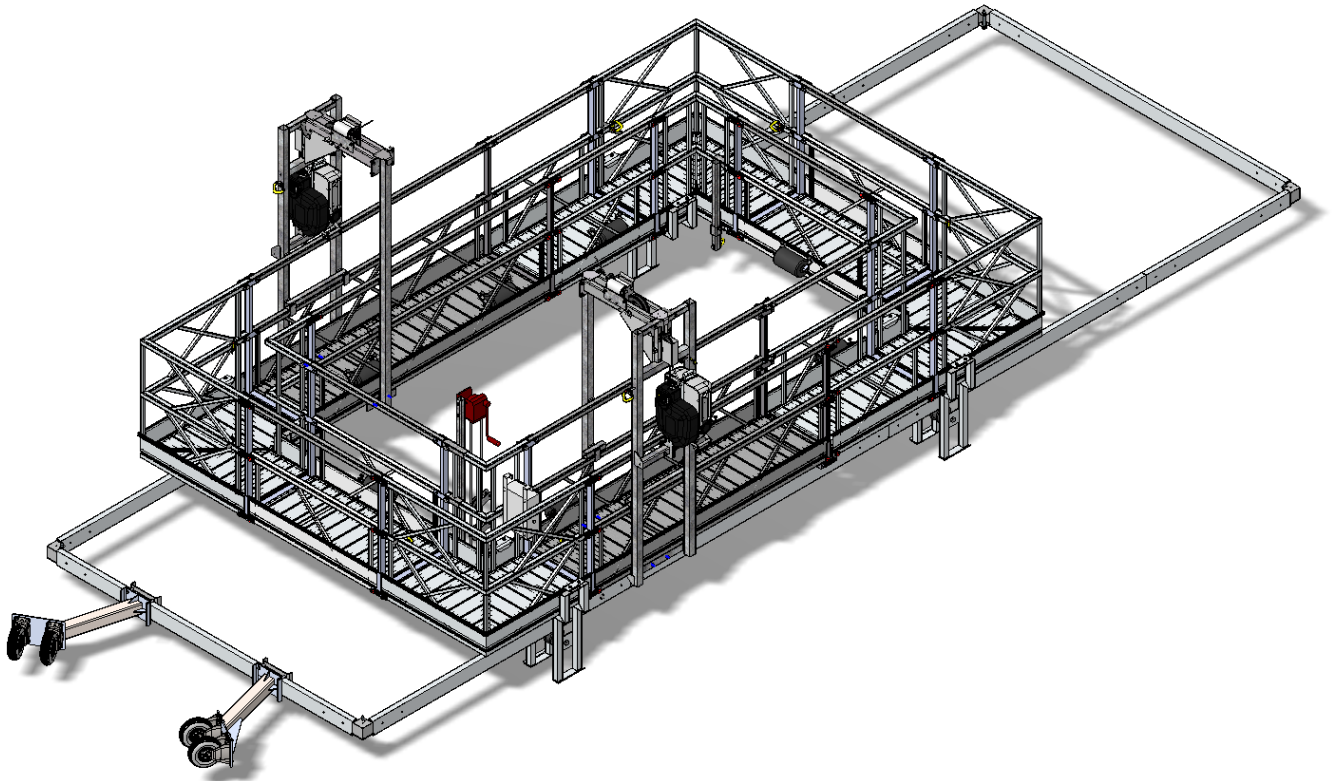

In compliance with the Machine Directive 2006/42/EC.
EN1808:2015 was used as guiding base for the design.

- This manual should be thoroughly read and understood before start of operations.
- All persons must be trained in the use of the equipment, its operational and safety features, and they must also be capable of carrying out the daily checklist.
- Only authorized and physically fit persons shall operate the equipment.
- Any manoeuvre in conflict with these guidelines is on one's own responsibility and may result in serious injuries
- This manual should be kept close to the platform at all times.

Only use original POWER CLIMBER parts and steel wire ropes.

Manufacturer

Power Climber BVBA
Satenrozen 7
B-2550 Kontich
Belgium

www.PowerClimber.be
Tel.: +32-3-451.05.00
Fax: +32-3-451.05.01
E-Mail: info@PowerClimber.com

Table of Contents

1	General View.....	3
2	Specifications.....	4
3	Rigging of the Steel Wires at the Nacelle.....	4
4	Assembly of the BAP 360°.....	5
5	Overview of Assembled Platform.....	21
6	Operation of the Blade Access Platform.....	23
7	Instructions & Precautions Before Starting and During Operation.....	25
8	Hoist Specifications and Features.....	27
9	Reeving of Steel Wires.....	28
10	Maintenance.....	30
11	Troubleshooting.....	31
12	Safety Features.....	32
13	Steel Wire Specs and Inspection Criteria.....	34
14	General Caution And Precautions.....	35
15	Daily Test.....	36

1 General View

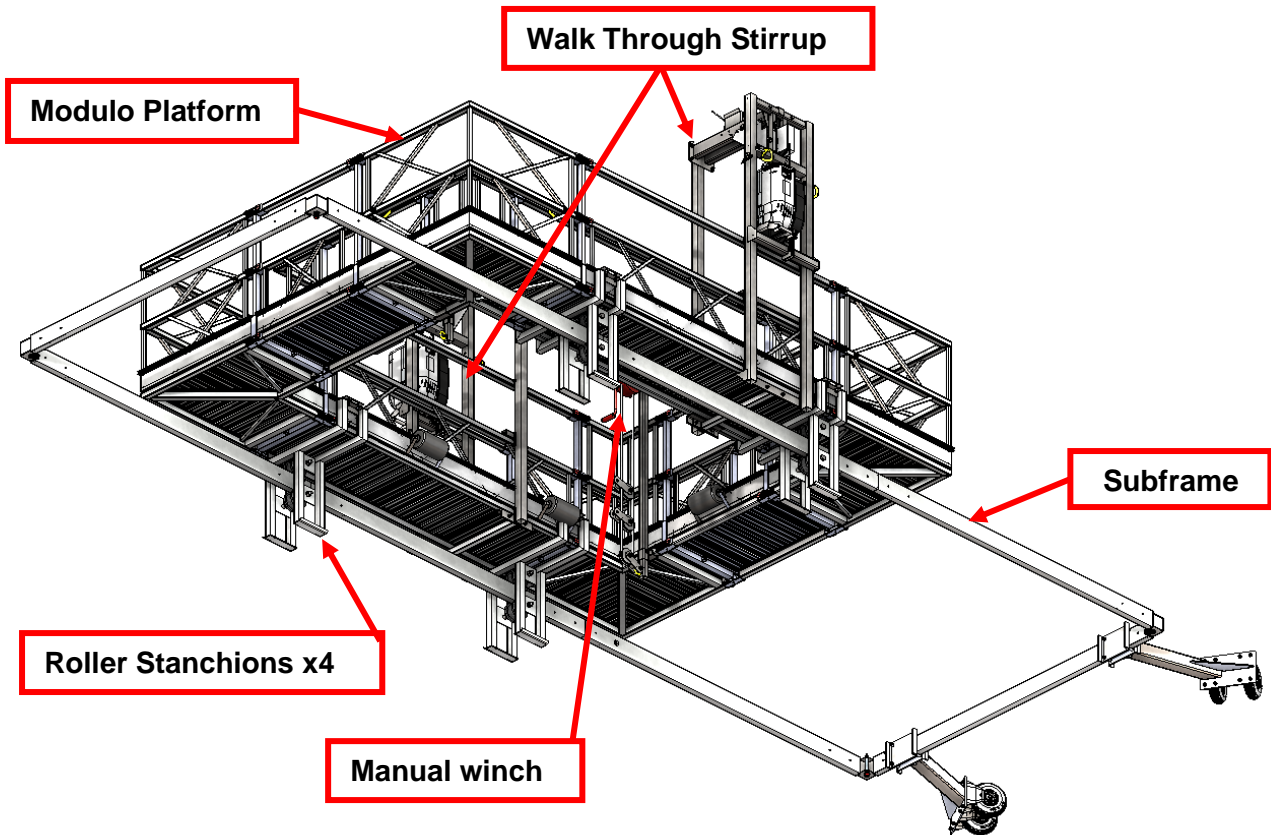

2 Specifications

Verification needs to be done to make sure that the size of the BAP platform is suitable for the given blade parameters and the planned work. Form with blade dimensions and parameters to be completed.

2.1 General Specifications

The platform is built with Power Climber Modulo Platform elements. Two Titan hoists type 653-CE are used to power the platform. Attached to the bottom of the rectangular platform is an aluminium subframe. The subframe is actuated with a manual winch to pull the platform away from the tower to access the blade. Double pneumatic rollers are used to engage the tower and roll along during ascent and descent.

2.2 Specifications for the ULTRAMAX lay-out

Total self-weight	1075 kg
Max. Payload	225 kg
Lifting capacity Titan hoists 2 x 650 kg	1300 kg
Max number of persons	2
Min number of persons	2
Lifting speed	8,5 m/min
Max Distance from Tower to Blade Tip	10,4 m
Min. Distance from Tower to blade	840 mm
Distance between suspension wires	2960 mm
Overall internal Dimensions L x W	4390 mm x 2200 mm
Total Height	2850 mm
Power Supply	3x400V/50 Hz (3Ph+N+E)
Power rating Titan hoists	2 x 1.3 kW
Max wind speed not continuously guided	10 m/sec
Max wind speed continuously guided with tag line	12,5 m/sec

3 Rigging of the Steel Wires at the Nacelle

- Rigging of the steel wires may only be done by trained installers.
- Rigging points must have a minimum rating of 3 x WLL = 3 x 650 kg
- When using slings, use 1 sling for the safety wire and 1 sling for the suspension wire.
- Minimum rated load of slings is 2000 kg (Green Slings)
- Only steel wires recommended by Power Climber Wind may be used.
- The top limit striker plates can be fixed to the suspension wires under the hook before lifting the wire to the nacelle. This to avoid the need to install the top plate from the platform.

The distance from the striker plates to the nacelle has to be carefully determined so to **limit the angle of the steel wires to maximum 15°**. This distance has to be calculated with the specific turbine parameters.

4 Assembly of the BAP 360°

NOTE: Length to be measured between bottom holes of sideframe.

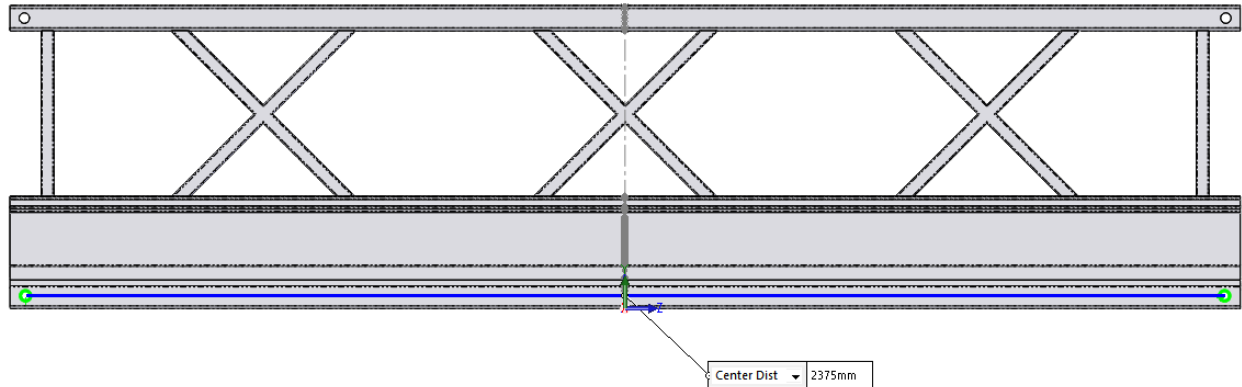

4.1 Bill of Material

Before assembling the BAP 360° make sure following components are present:

For the MODULO® platform:

- | | | |
|----|---|----------------------------|
| A. | 4 x Corner section with 2 U frames attached | (PN 61054+2 x PN 61041) |
| B. | 2 x Deck section 1274 mm | (PN 61025-1274) |
| C. | 4 x Side frame 1274 mm | (PN 61027-1274) |
| D. | 4 x Guard rail 1274 mm | (PN 61026-1274) |
| E. | 2 x Deck section 2375 mm | (PN 61025-2375) |
| F. | 4 x Side frame 2375 mm | (PN 61027-2375) |
| G. | 4 x Alu Guard rail 2375 mm | (PN 61026-2375) |
| H. | 2x Extra U frame | (PN 61041) |
| I. | 2 x Deck 980 mm | (PN 61025-0980) |
| J. | 4x Side Frame 980 mm | (PN 61027-0980) |
| K. | 4 x guard rail 980 mm | (PN 61026-0980) |
| L. | 120 x SafeFix pins | (PN 61049) |
| M. | 2 x Walk-through Stirrup | (Assembly) |
| N. | 8 x Soft Wall Roller | (PN 61046) |
| O. | 2 x Titan Hoist | (PN 9091-1 3 phase unit) |

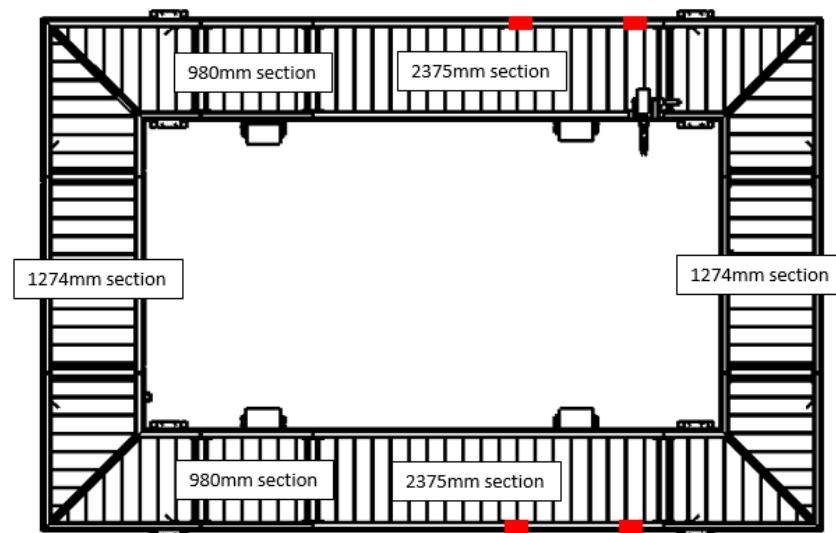

For the Sub-Frame:

- A. 1 x BAP 360° Stabilization Frame
 - 4 x Caster Assembly (Assembly)
 - 6 x Tubes 130x50x4 L = 2686mm (PN P-6360-019)
 - 2 x Tubes 130x50x4 L = 1500mm (PN P-6360-084)
 - 2 x Tubes 130x50x4 L = 3081mm (PN P-6360-087)
 - 6 x Connection piece (Assembly)
 - 4 x Corner piece (Assembly)
- B. 4 x Roller support (Roller Stanchion) (Assembly)
- C. 1 x Winch Assembly with steel wires and 3 pulleys.
- D. 1 x Anchor Assembly

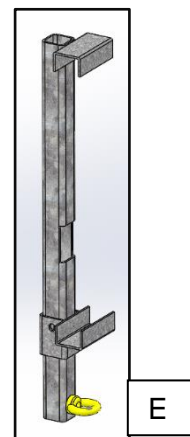
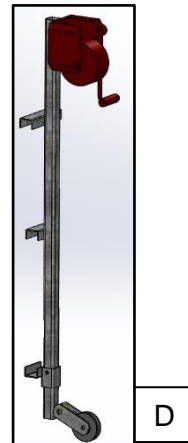
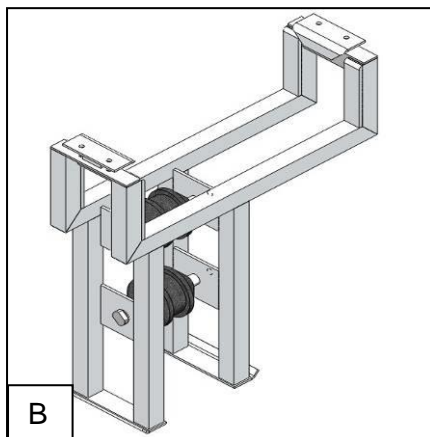
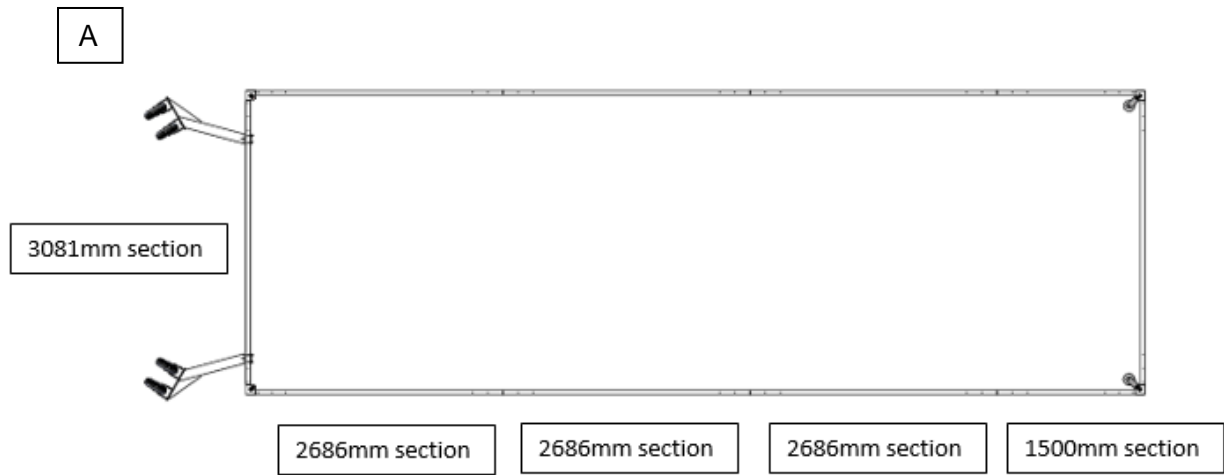

4.2 Assembly of the Modulo platform with stirrups

General information on modulo platform assembly

The modular design of the MODULO® suspended platform allows you to modify the configuration of the standard components to obtain the size platform required. These components are secured together by using the patented SafeFix pin system, a one step “insert and snap” method to assemble MODULO® platform components. The slotted pin is fixed in place by a spring mounted on the stirrup or U-frame.

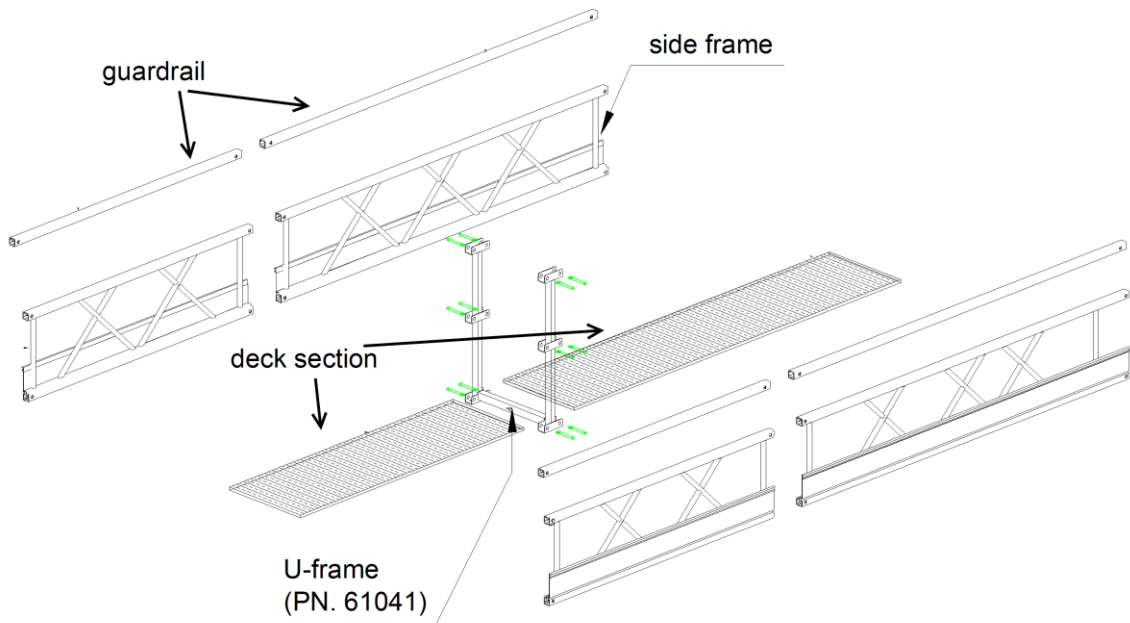

General information on SafeFix pins

To connect the platform components use the SafeFix Pins. Push the pins through the holes, keeping the slot horizontal (Fig 1). In this position the pin is secured by a spring catching in a groove of the pin. To remove the SafeFix pin, turn the pin 90° and push the pin out. (Fig 2&3) The pins can be positioned with a screw driver and a mallet.

Insertion of the SafeFix pin

- Line the pin up with the hole, so that the slot at the base of the pin is horizontal.
- Push the pin in from outside until the spring clicks in the grooves on the shaft of the pin. If required, rotate the pin till the slot is horizontal and the springs are in place.
- Make sure the pin is secured.



Fig 1

Removal of the SafeFix pin

- Rotate the pin ¼ turn till the slot is vertical (and the springs are no longer in the grooves) and pull the pin out.



Fig 2



Fig 3

First assembly of the platform

- Start assembling the platform according to the pictures below. Do this twice.
- Do not put the Alu Guard rail 2375 mm in place yet. This will be done after mounting the stirrups.

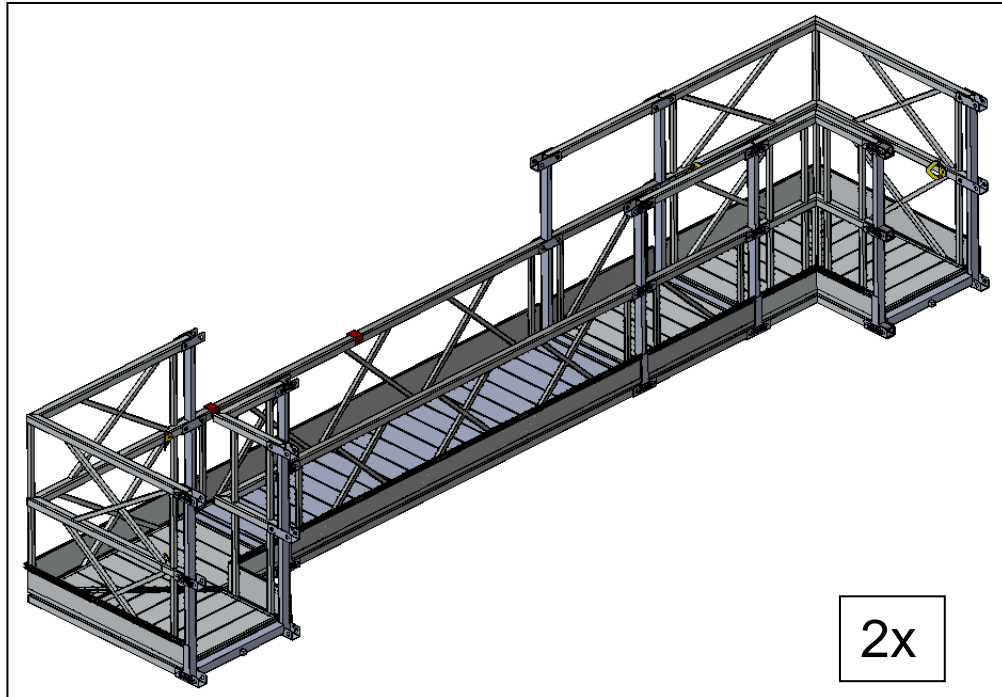

- Put the 2 elements on its side and assemble the roller support units to the corner sections. Fix the units with 2 clams to the platform.

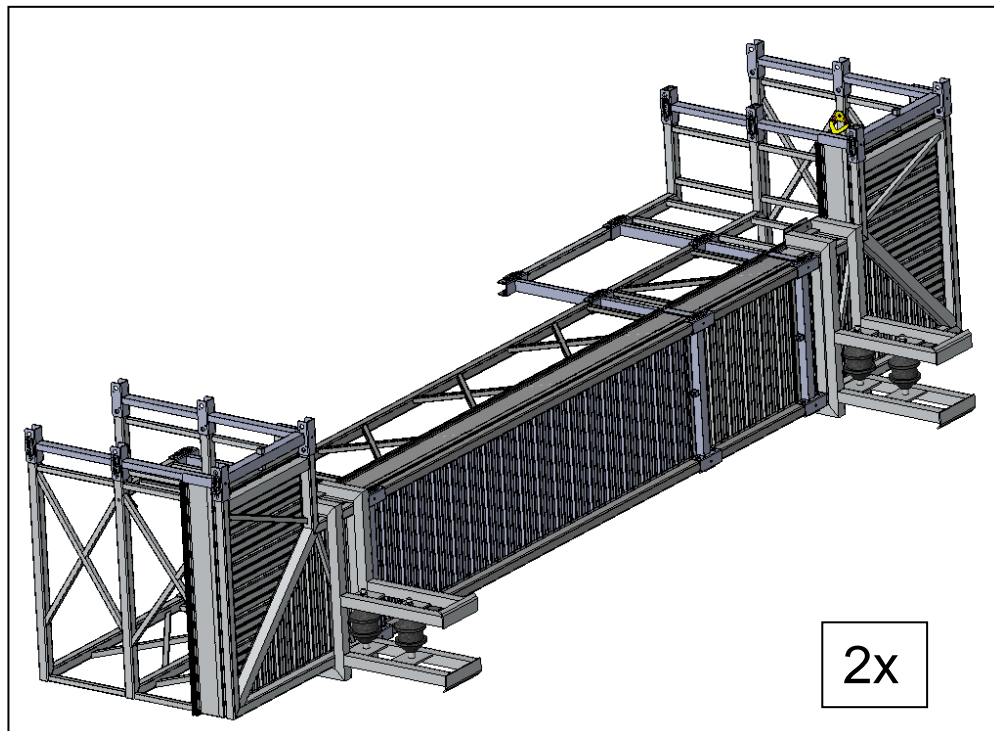

- Install support and put the platform-half up again.

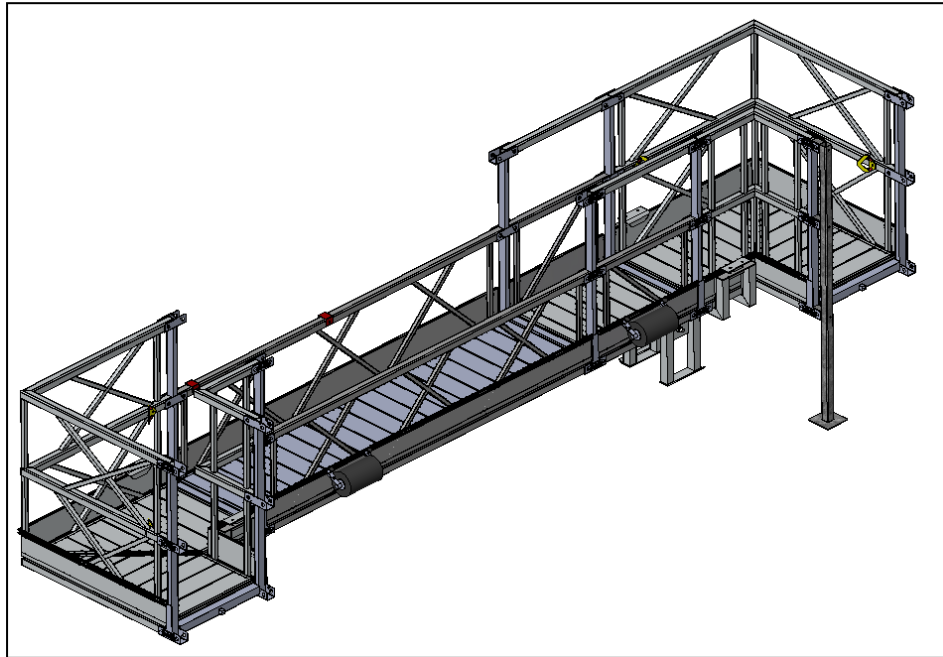

- Assemble the stirrups on the platform.
One stirrup will be provided with guiding springs, make sure to assemble this one on the **left** side of the platform (when looking towards tower).

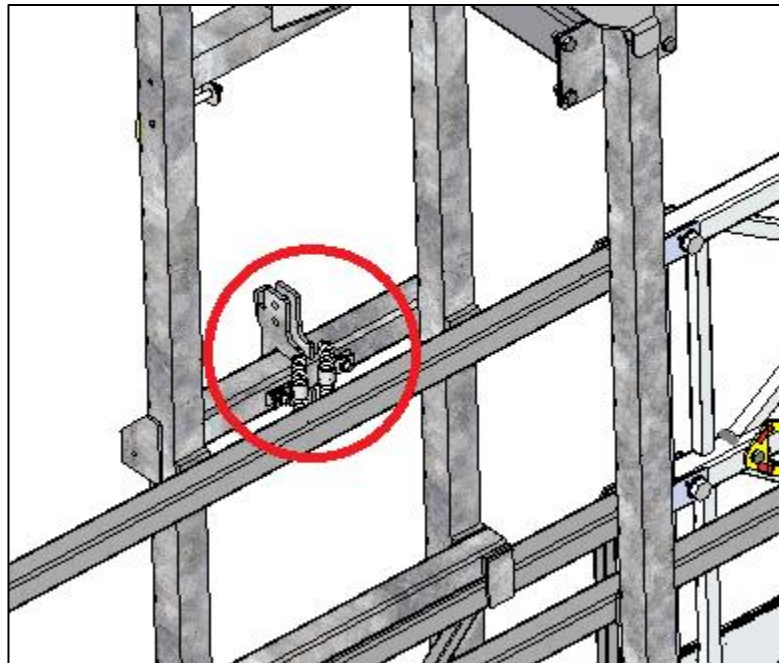

The one without the springs is the **right** side.

- Make sure the big roller on top so on the tower side. Mount the guardrails afterwards.

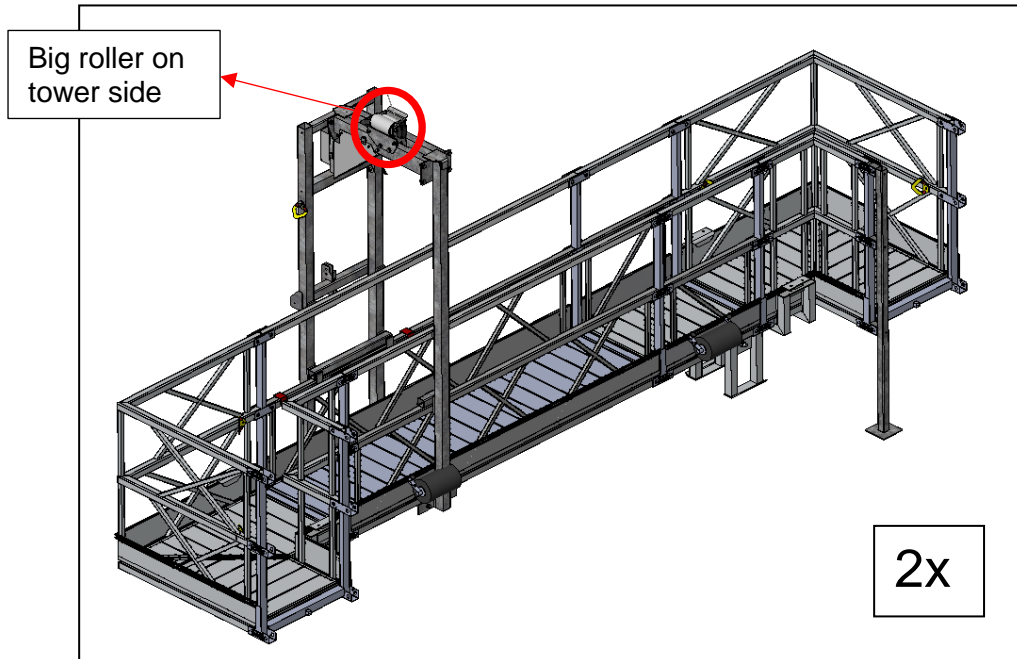

⇒ Make sure that the stirrups on both platform halves are located at approximately the same location

- Mount the back support that hold the steel wire of the subframe.

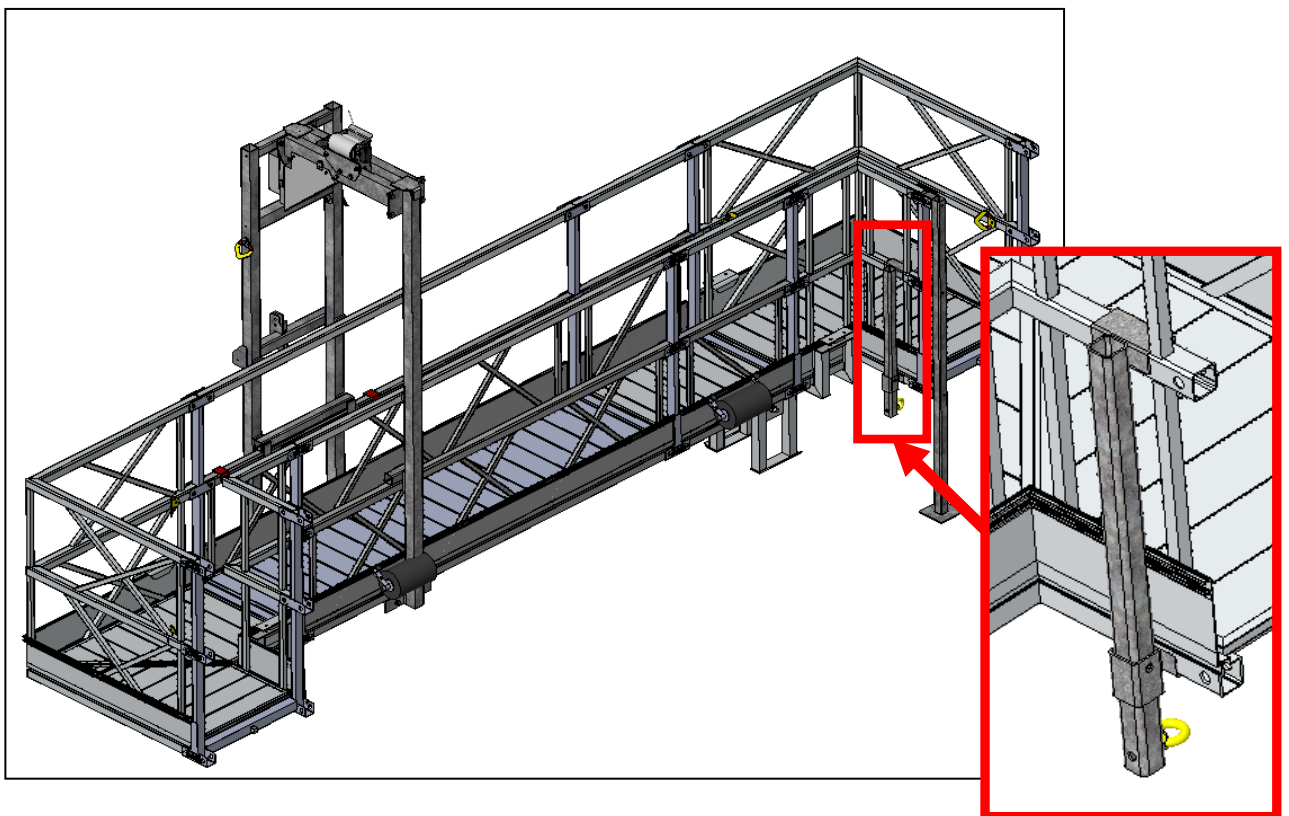

- Mount the support with the winch

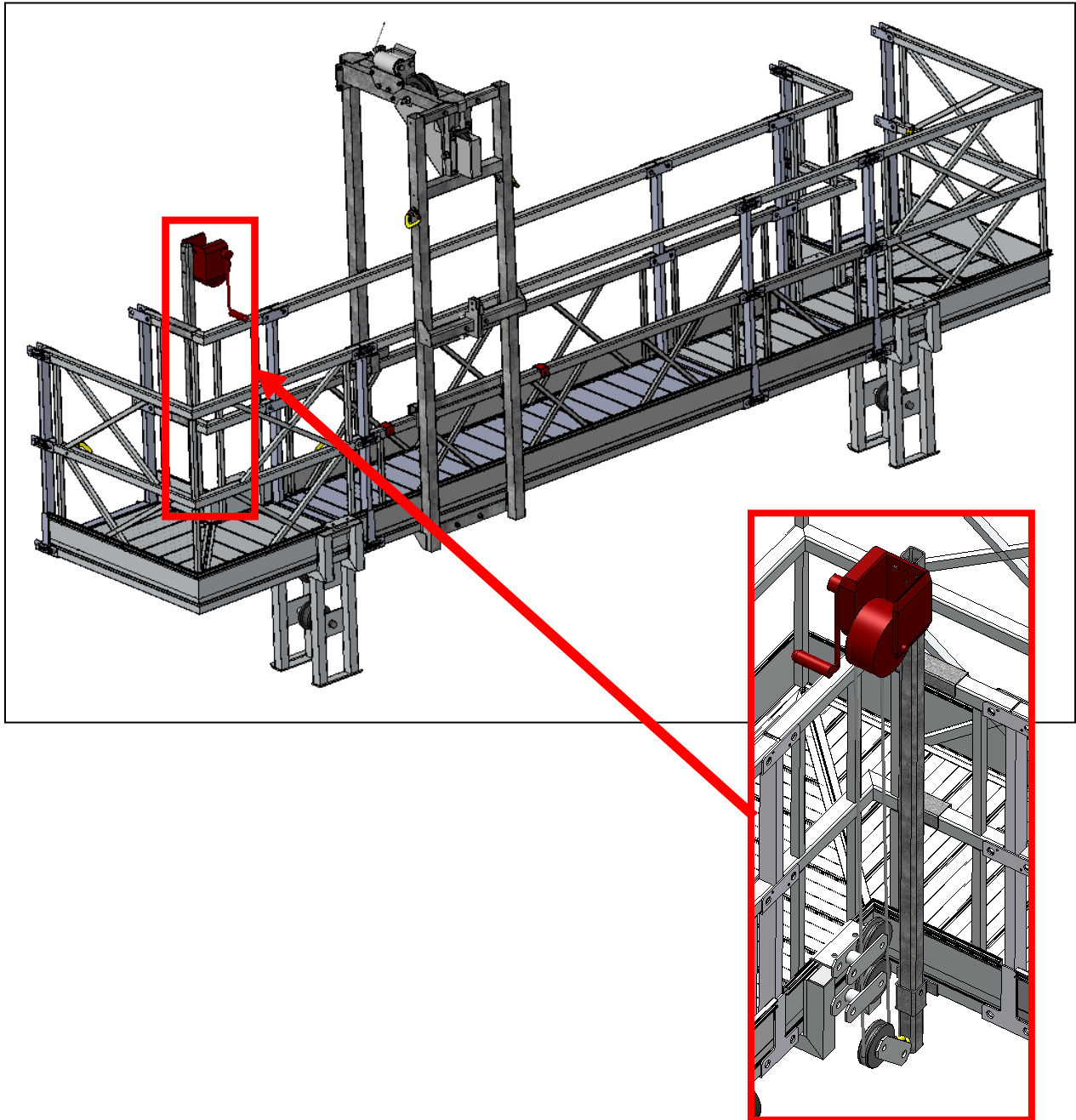

- Now start assembling the 2 pieces of the platform according to pictures below.

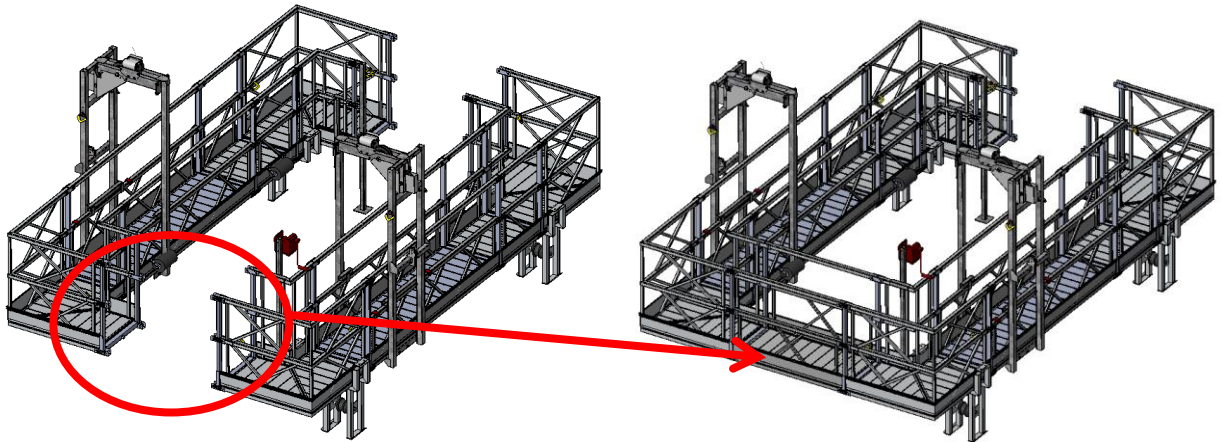

On the other side mount one side frame and guard rail where no supports are present. After that remove the supports.

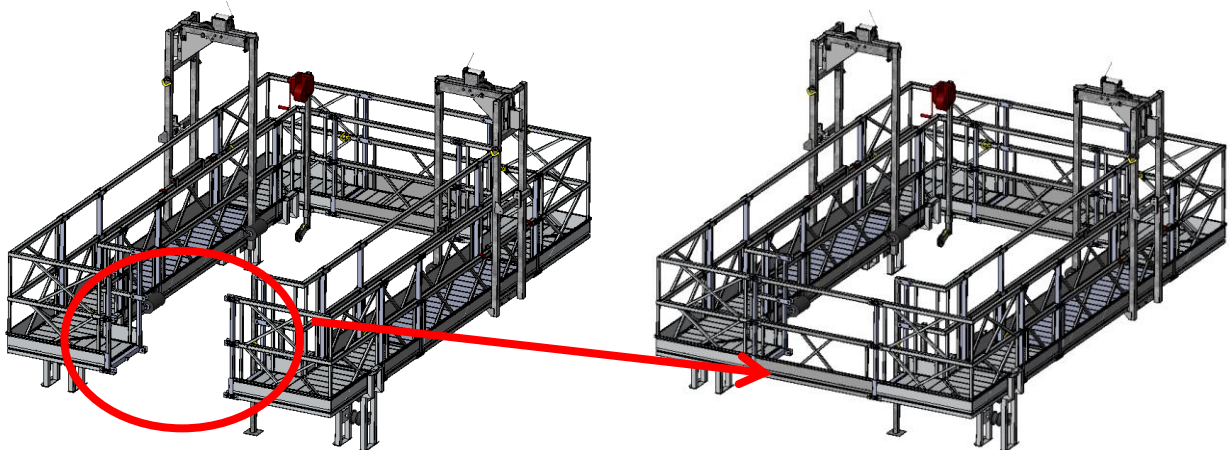

Finally assemble the last pieces of the platform.

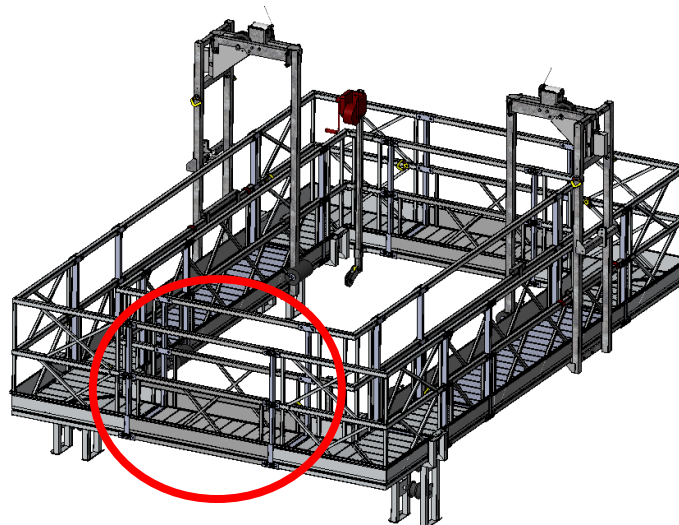

Assembly of the platform starting from the trailer

On the picture below the platform is positioned that the front part of the trailer has the part of the platform that needs to be positioned towards the tower. This can be reversed that the rear of the trailer has the part of the platform that needs to face the tower.

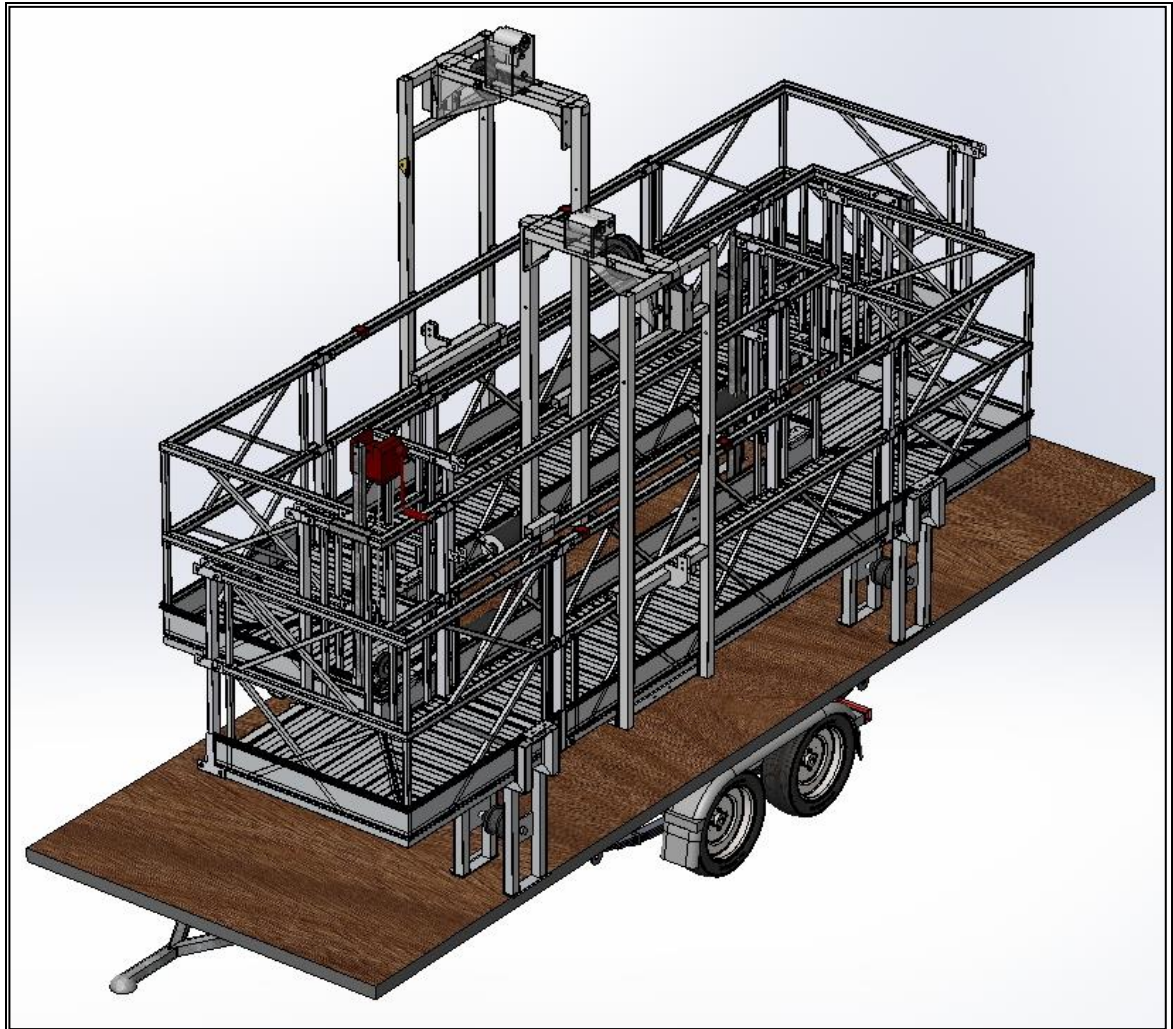

First you need to mount the hoists on the stirrup. You can shear in the steel wires and use it to lift the hoist to the proper positions. Make sure that on both stirrup sides, the black cover of the Titan hoist is facing the tower.

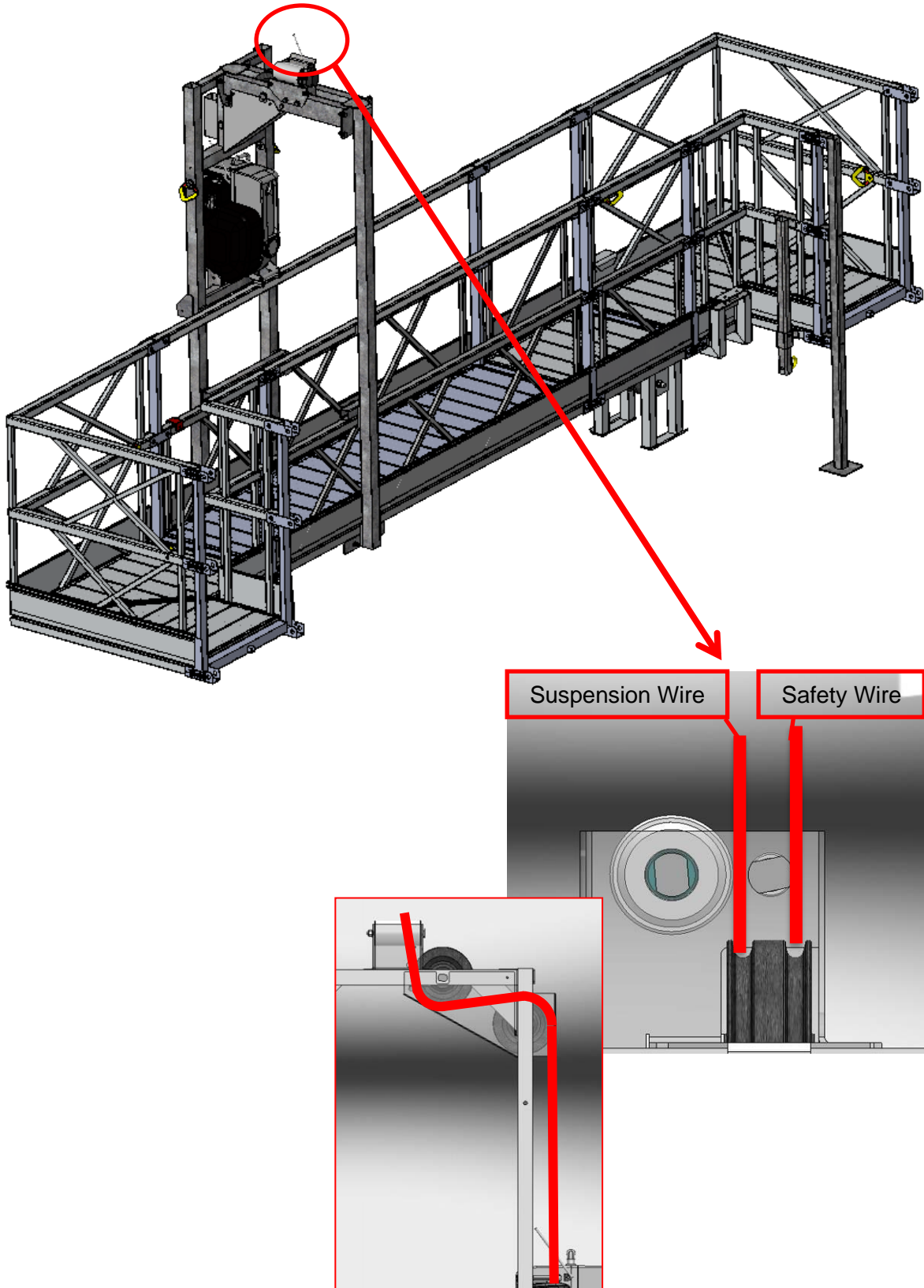

After that the hoist are properly mounted and the wires are attached correctly you can start lifting the platforms. Move one half of the platform to the side and put it on the ground. Lift the other half up and remove the trailer.

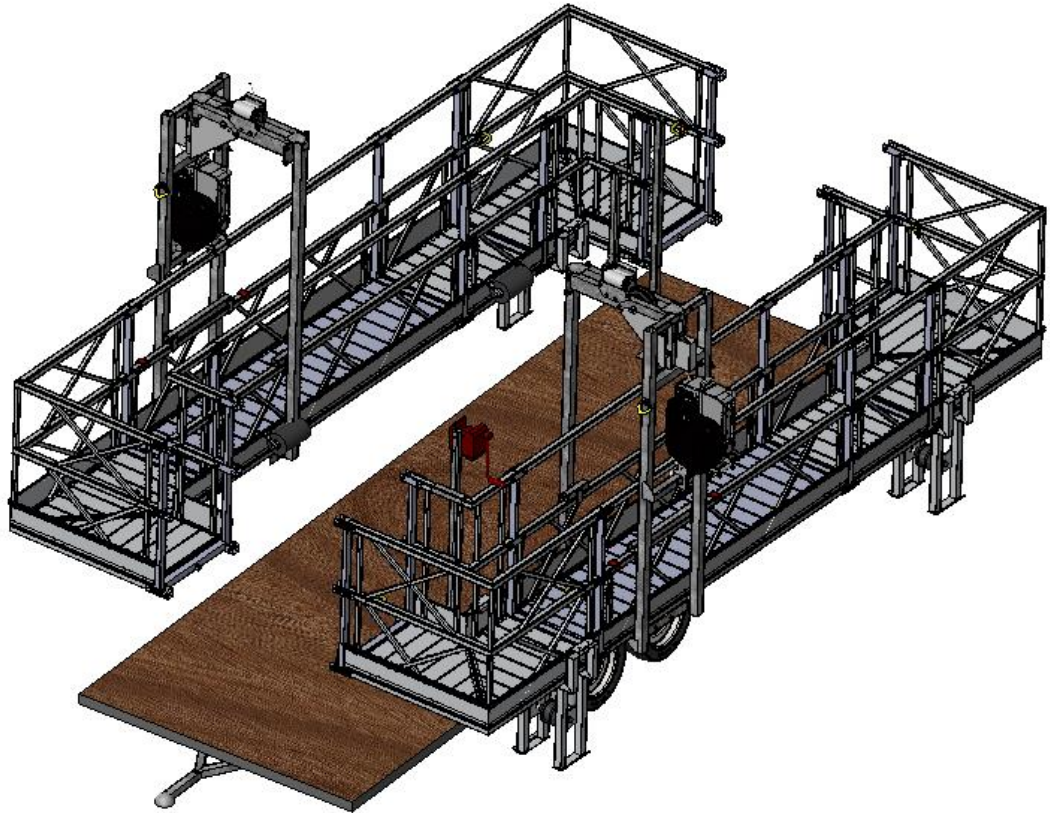

Now position the half that is hanging in the air according to the pictures below.

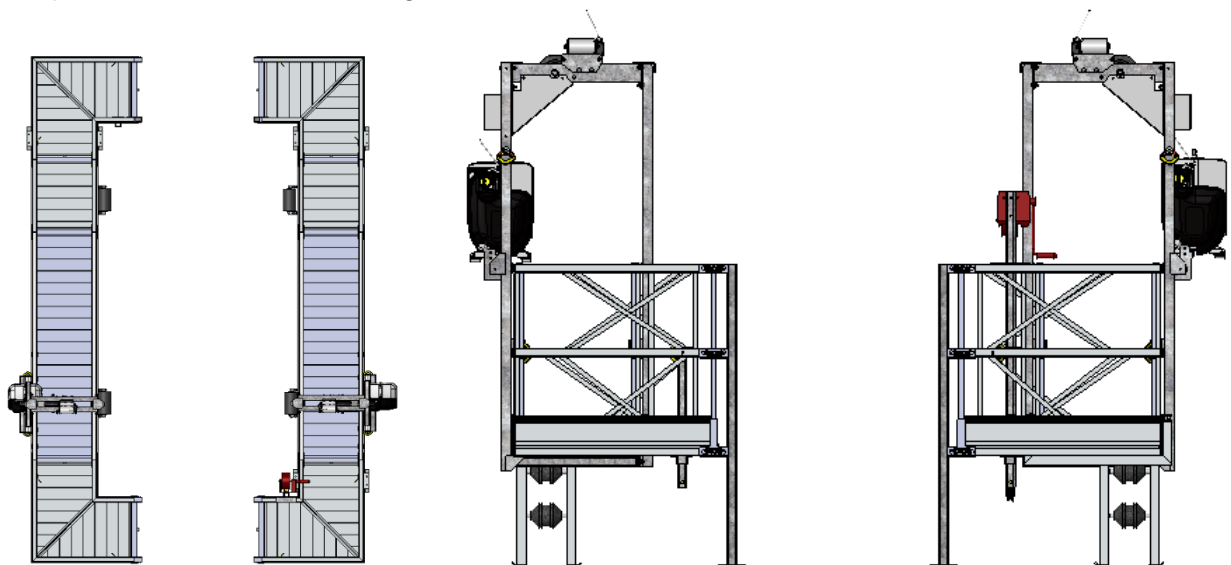

Now start assembling the pieces of the platform on the side where no supports are present.

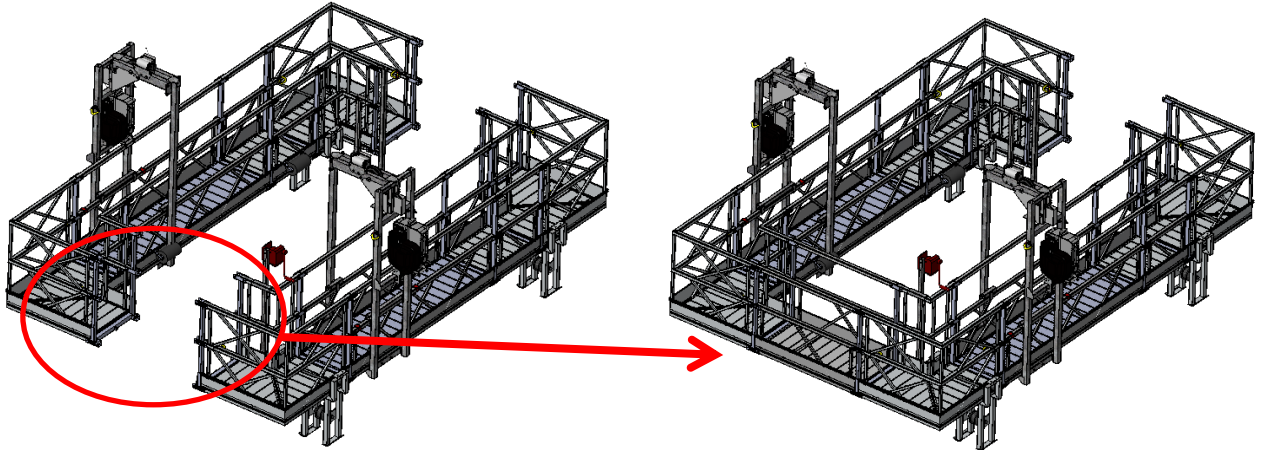

On the other side mount one side frame and guard rail where no supports are present. After that remove the supports.

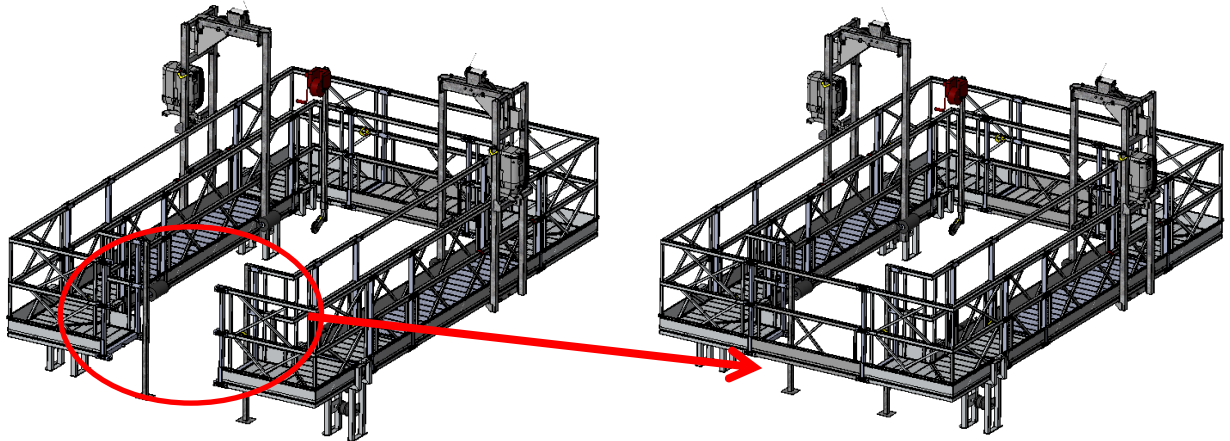

Finally assemble the last pieces of the platform.

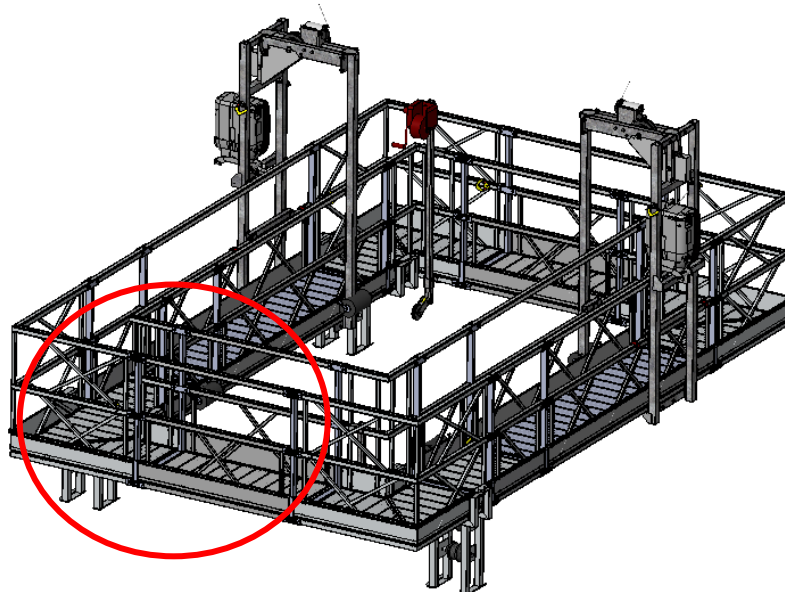

Assembly of the subframe

Depending on the size you want to build you will need different tubes. See '4.1 Bill of Material' for the needed materials. Use the following assembly guides to complete the subframe assembly.

Assemble the straight tubes together with the straight connection pieces and the corner pieces to a straight tube and a cross tube by means of bolts M12x70.

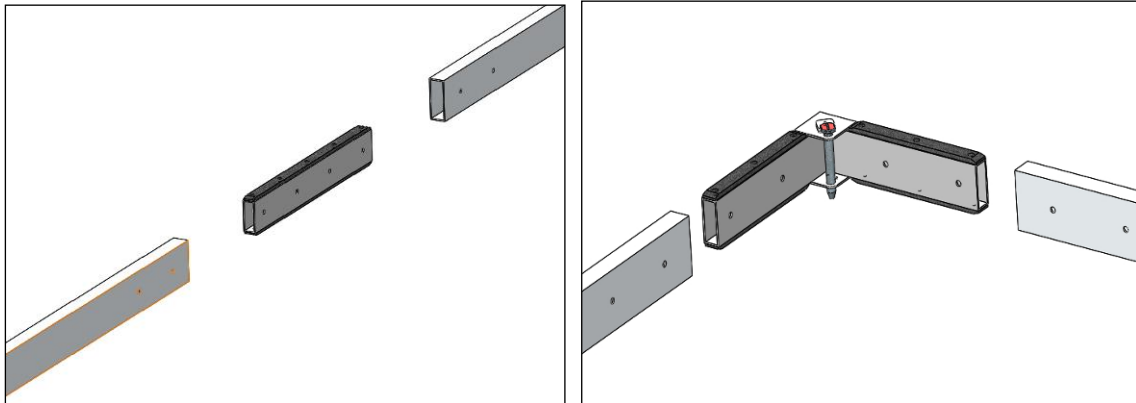

Fixing cable weights

Fix 1 cable weight of 10 kg to the suspension wire and 2 cable weights to the safety wire. Suspension wire need to be able to rotate freely.



Mounting of the tower rollers

Mount the tower roller assembly to the front tube using the connection plate, 4 spacers, 4 M12x90 bolts and M12 washers and nylock nuts.

Use the following tightening sequence and torque specifications.

Make sure that the rollers are perpendicular to the turbine's tower.

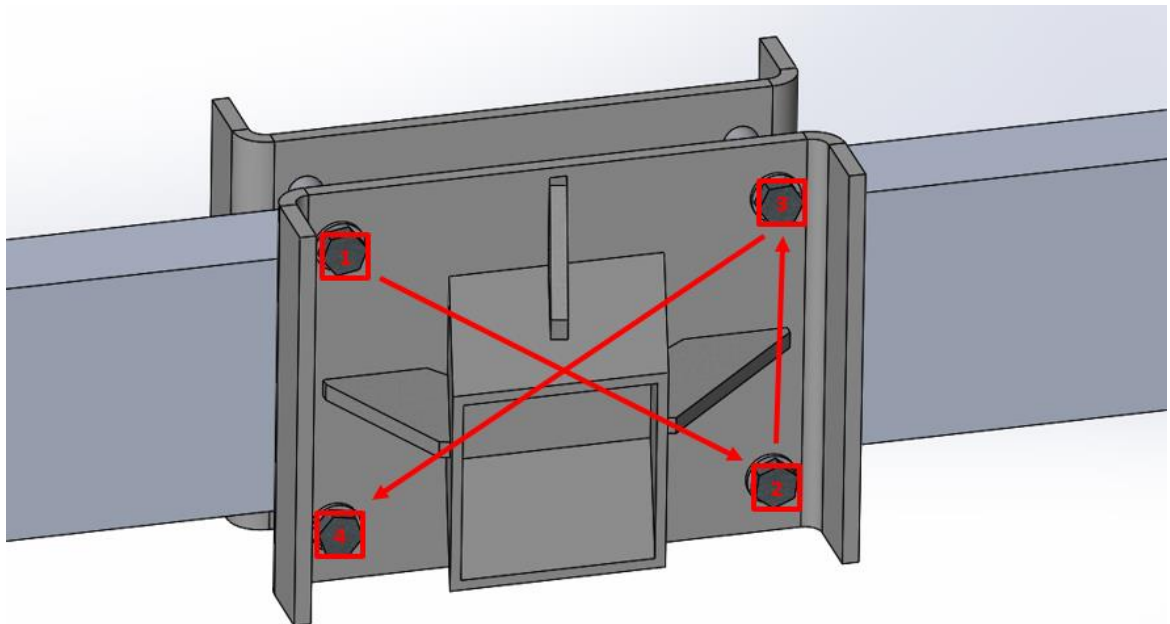
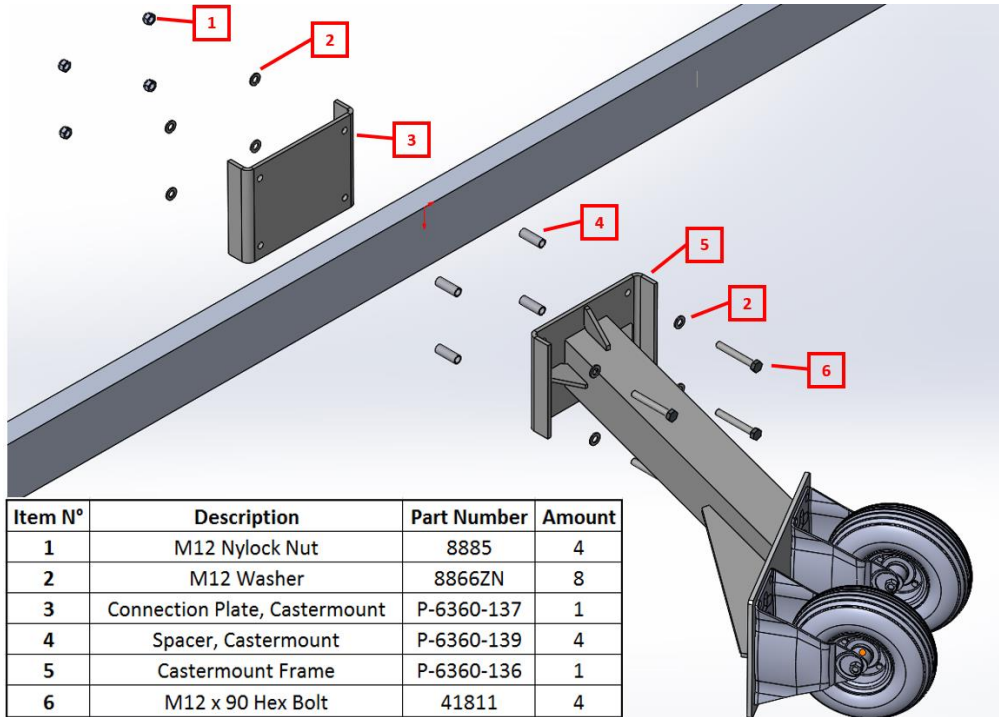

- 1) First tighten the four nuts without applying any force
- 2) Next tighten to 10Nm in the cross pattern sequence shown above
- 3) Finally torque down to 25Nm, also following the cross pattern above.

Mounting of the Central Control Box

Mount the CCB on the guardrail of the platform, closest to the tower.

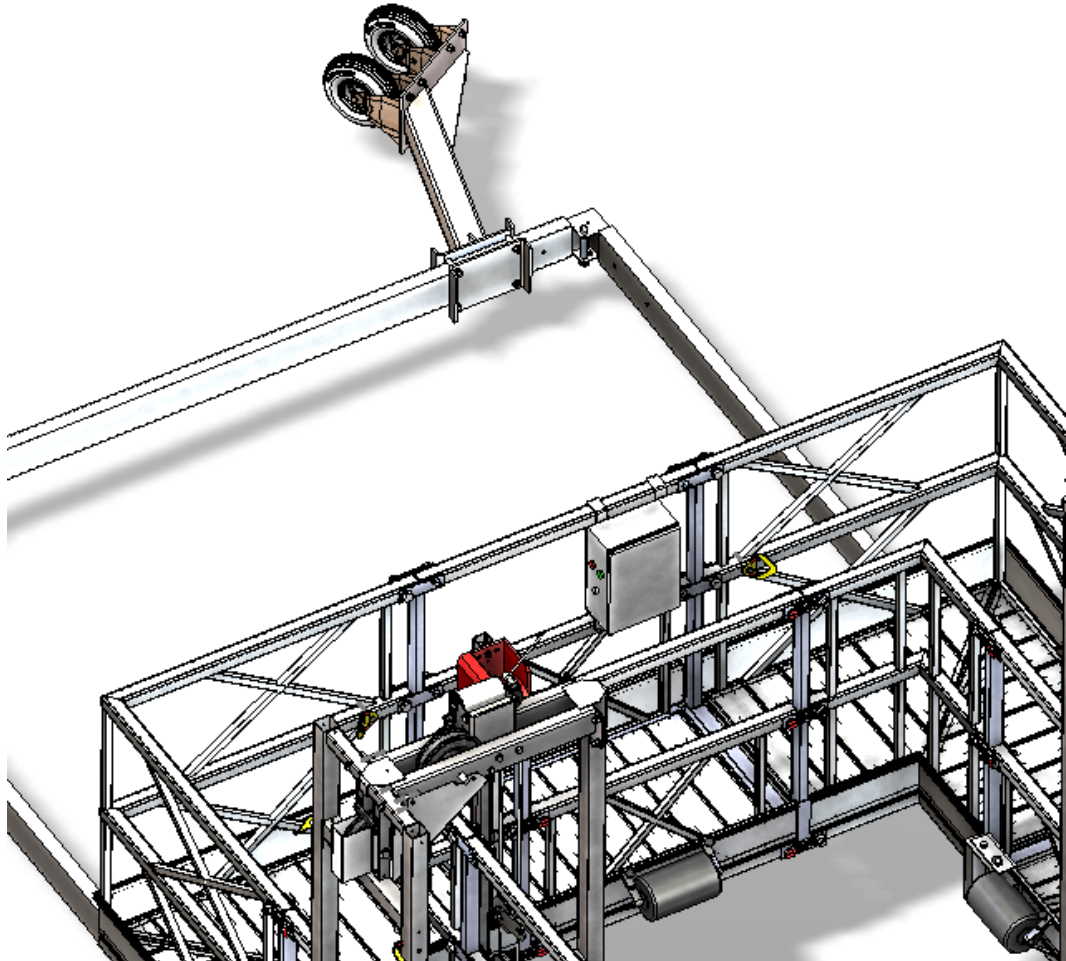

5 Overview of Assembled Platform

5.1 Ultramax layout

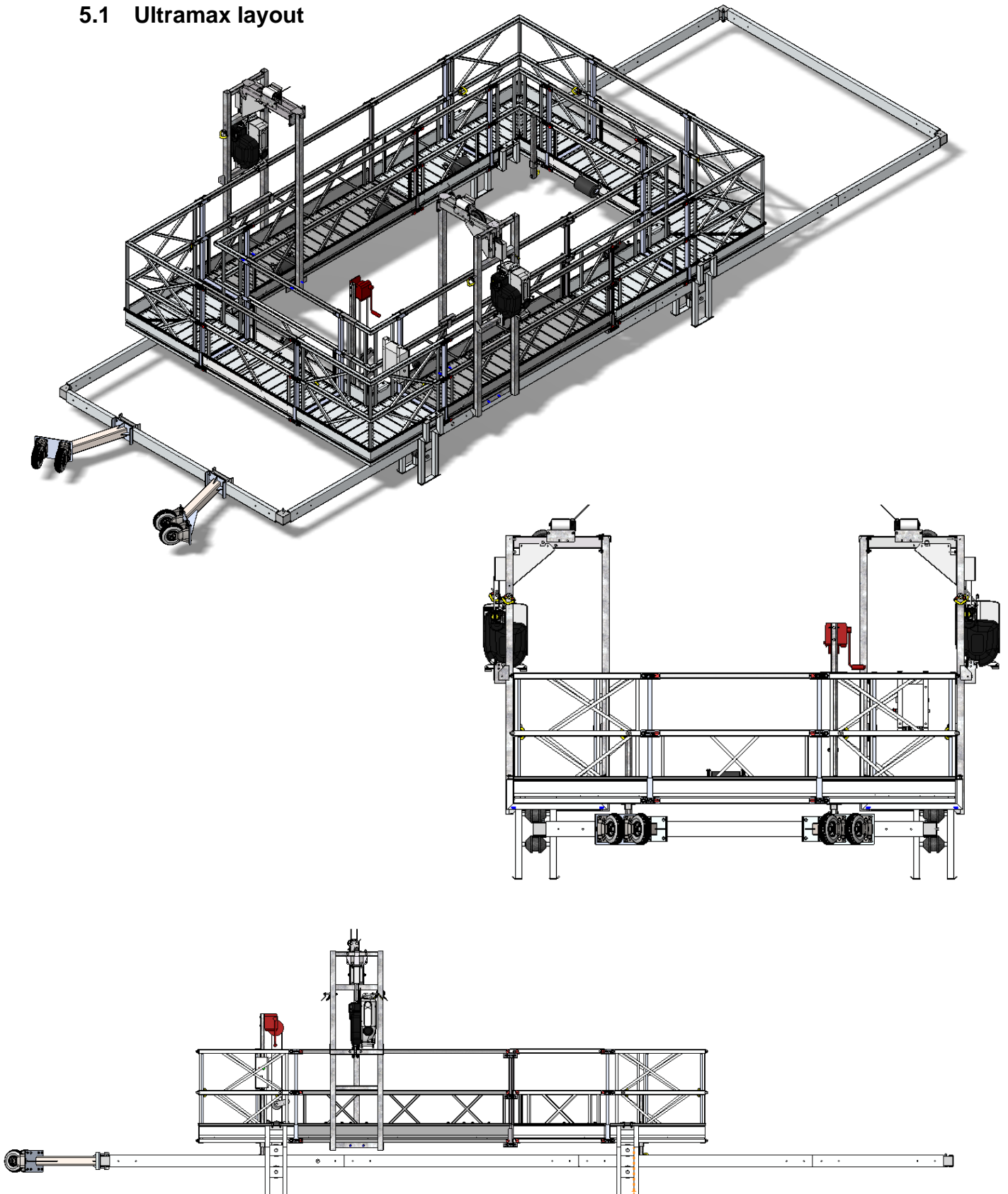

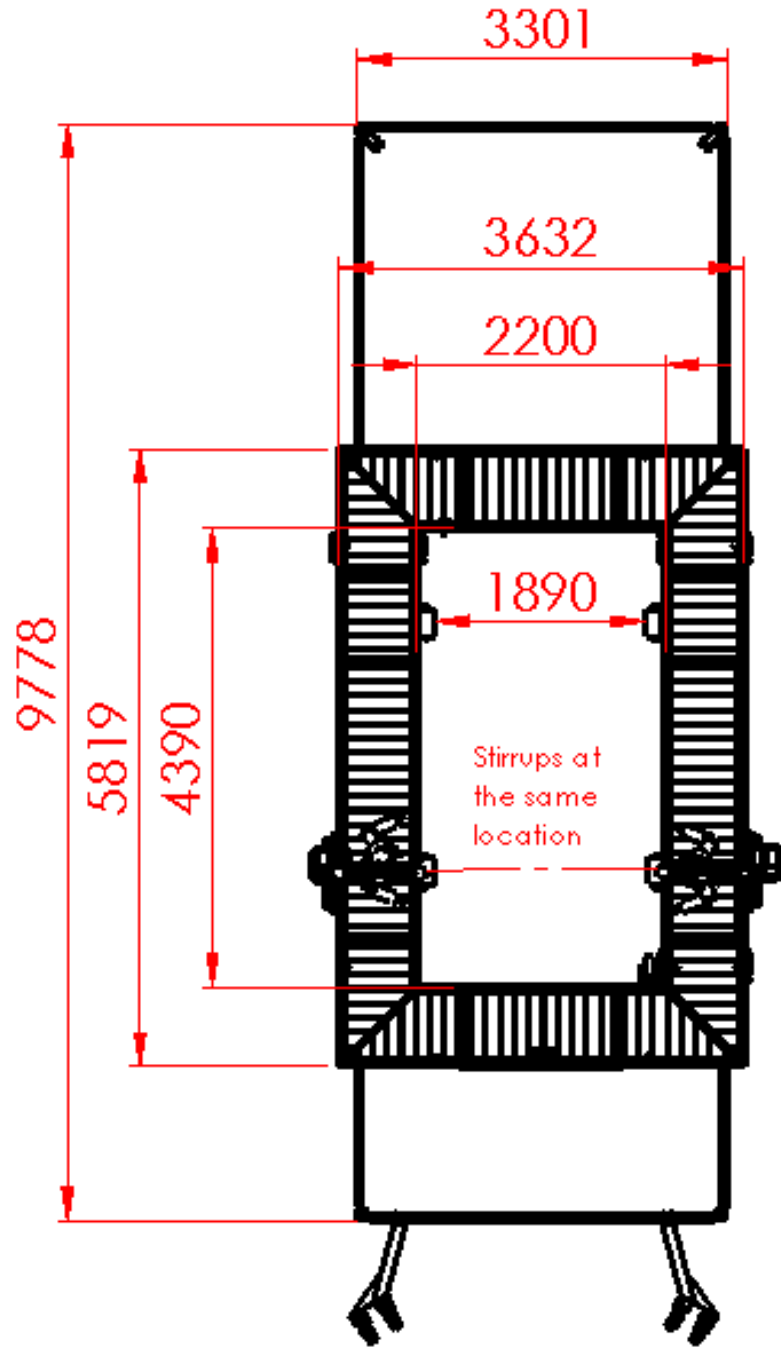

DIMENSIONS OF ULTRAMAX LAYOUT

6 Operation of the Blade Access Platform

The 2 Titan hoists on the BAP platform are controlled from the Central Control Box (CCB).



Pic 1 Selector switch for pendant control



Pic 2

Make Sure that all the plug connection are made and closed properly. Connect the power control Plug.

- To operate the platform upwards, press the UP button. Both Titan hoists will start simultaneously. Buttons are of the dead man type. See Picture 1
- To operate the platform down, press the down button.
- In Case of Emergency, the Emergency stop, will cut the power to the hoists.
- The control Box is provided with an automatic Levelling device, becoming active when the inclination exceeds 6°. The system will cut the up-direction of the highest hoist and the down direction of the lowest hoist, allowing only those movements to correct the level.
- On the control Panel there is also a Selector switch, which makes it possible to select to operate either the left hoist, the right hoist, or both hoists. This will allow a manual correction of the inclination of the platform. See Picture 2

- A Green Pilot light will be illuminated when the power is connected correctly. Change 2 phases in case pilot light does not come on when power plug is inserted to correct the Phase sequence.
- A Red Problem light will be illuminated in case of
 1. Overloading of one of the hoists.
 2. Emergency stop is pressed.
 3. Thermal Protection of one of the hoists is activated.
 4. Plugs of the hoists are not connected.

Note: On the right hand site of the CCB there is a selector switch to control the platform from a Pendant control.

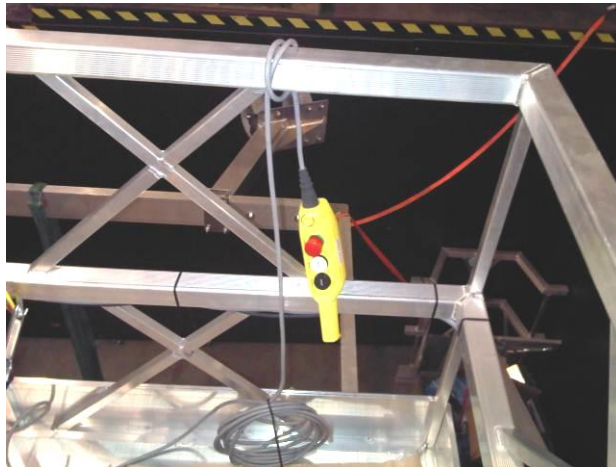

When the selector is in horizontal position control from the Central box and from the pendant are enabled. When the selector is in vertical position, only controls from the central box are enabled. The Pendant controlled is wired into the circuit after the automatic level control, so in case there is a failure with the automatic level module, the normal control from the central box is prevented, but it remains possible to control the platform with the Pendant. In that case the level of the platform needs to be maintained by operating the brake on the hoists, if necessary.

NOTE: the emergency button on the Pendant will disable operations on the pendant as well as on the CCB.

In Case of power failure the platform can be lowered by releasing the brake on the Titan hoists manually.

7 Instructions & Precautions Before Starting and During Operation

- Operators must wear a safety harness and connect the safety hooks to the yellow fixing points provided on the platform.
- Means of communication, (Mobile Phone) must be available on the platform.
- It is recommended to have an Emergency rappelling kit on the platform.
- Make sure that the blades are in the parked (stand still) position with one of the blades pointing down vertically, and that the brakes are on.
- Platform may only be used not guided when the wind speed is less than **10 m/sec**. Double check the wind speed before starting.
- If using a tag line, the platform may be used only when the speed is up to **12,5 m/sec**.
- A stand-by person or team members must be available on the ground for emergency cases or to handle the tag line when the wind speed is more than **10 m/sec**.
- It is possible to have increased wind speed during operation on the blade. As long as the platform is over the blade there is no problem. In case the platform needs to be operated down, at least one tag line is required, fixed on the safety hook attachment point at the rear of the platform on the wind side, and lowered to the ground for the ground team to give the relevant amount of pulling force to keep the 2 rollers in contact with the turbine tower. Therefore a tag line of sufficient length should be on board of the platform during each operation.
- Because the stirrups are located towards the inside of the tower, the BAP will tend to tilt away from the tower on initial lift off. This is normal and to be expected. As the platform is pushed away from the tower the platform will tend to level out. It is recommended to raise the platform off the ground and immediately position the sub frame to the middle position.
- In case the wind speed is close to the maximum value of 10m/sec, the sub frame must be repositioned to the minimum position bringing the platform closer to the tower. This way the moment arm for the wind force on the platform will be reduced. The platform might be tilted slightly backwards in this case.



- When reaching the Tip of the blade use the winch to bring the blade in the middle of the opening in the platform. If needed the platform can be pushed side-wards..
- When going higher on the blade, make sure that the blade is only in contact with the rollers or the cushioning. Use the winch to keep the platform centric round the blade.

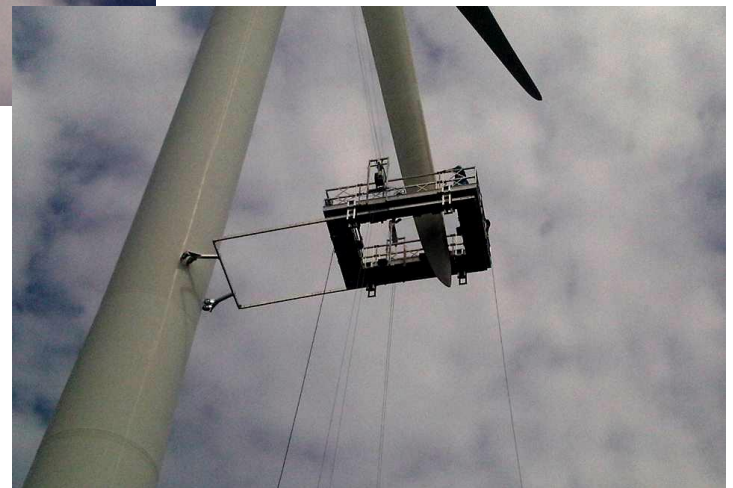

- When moving the platform UP or DOWN check the rollers on the towers to verify that the pressure on the rollers is not too much. (Rollers should only be slightly compressed). If needed the stirrups need to be repositioned. Move the stirrups closer to the front in order to reduce the pressure on the tower rollers. Move the rollers to the rear to increase the pressure on the tower rollers.
- When going up on the blade to the highest point, the top plate (which has been fixed to the steel wire during installation) will activate the Top limit switch and the UP and DOWN direction will be cut. To reset the, lower the hoist a bit by pulling on the yellow brake lever on the Titan hoist. Once the top plate is not in contact with the activating bar of the Top limit switch, the system is reset.
- **The loading on the platform should be uniformly distributed therefore DO NOT go with all 3 operators to the extreme ends at the same time.**
- **Only trained operators should be allowed on this platform.**

REMARK: When using a Generator to power the platform the capacity of the Generator should be Min 15 KVA with 16A 5 pins socket with an output of 3x400V+Neutral +Earth

8 Hoist Specifications and Features

TITAN Three Phase	
Type	TITAN 653
WLL	6500N (650 kg)
Current	2.5 A
Start current	7.5 A
Power	1.8 HP
SWR breaking force	52 kN
Climbing speed	8.0 m/min
Noise up	60 dBA
Noise down	64 dBA
IP-rate	IP 55
Hoist self-weight	45 kg



Top limit switch

Carrying handle

Safety rope
Slack rope lever

Suspension rope

Nameplate
(serial no.)

Motherboard
under the cover

Lower
carrying
handle

Power plug
10Pole

'No Power'
emergency
descent lever



Electric motor
under the cover

9 Reeving of Steel Wires

A. Reeve the suspension ropes in the TITAN hoist

At roof level, uncoil the suspension ropes and lay them on the roof surface. Attach the suspension ropes to the suspension system with the safety hooks fitted to the ropes and lower the ropes to the ground. Verify that the rope is long enough.

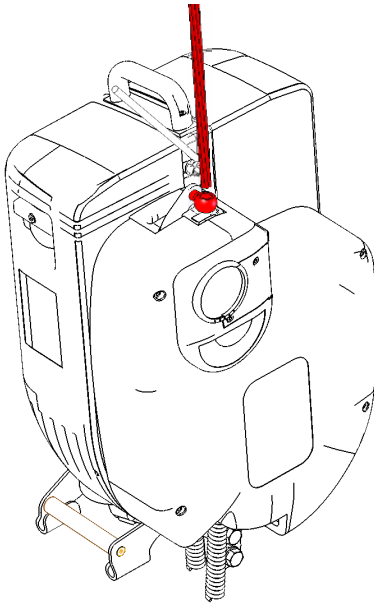

Tip: Before reeving the suspension rope, check that the overspeed safety device is reset by turning the yellow reset knob in the direction of the arrow (clock-wise).

1. Push back the slack rope lever and insert the suspension rope through the eye of the slack rope lever and into the hoist until it stops.
2. Push the 'up' button on the Control panel and the steel wire rope passes through the hoist automatically. The end of the rope will come out from the bottom of the hoist. Make sure the outlet is free and the wire rope can come out.

Tip: If there is any difficulty reeving the suspension rope it helps to put a small bend in the end of the rope before feeding it into the hoist.

B. Attach the TITAN hoist to the stirrup

1. Lift the TITAN up from the ground by pushing the 'up' button on the Control panel. Line up the holes in the stirrup bar with the holes in the stirrup.
2. Attach the TITAN hoist to the stirrup of the platform with M12 bolts and self-locking nuts. Make sure that the TITAN hoist is mounted with the main hoist label towards the inside of the platform.

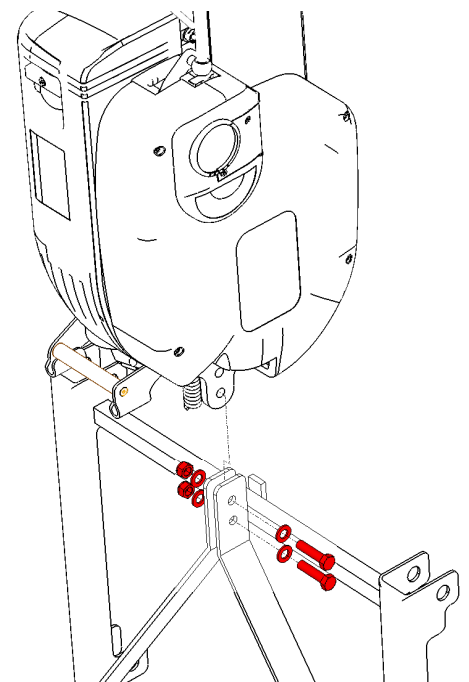

C. Reeve the safety rope in the TITAN hoist

At roof level, uncoil the safety ropes and lay them on the roof surface. Attach the safety ropes to the suspension system with the safety hooks fitted to the ropes and lower the ropes to the ground. Verify that the rope is long enough.

Push back the slack rope lever (or tension the suspension rope) to open the jaws of the slack rope safety device and push the safety rope through the slack rope compartment. Take out all slack by putting a weight on the tail end of the safety rope.

Tip: Separately reeving the safety rope and the suspension rope, will avoid getting them twisted together.

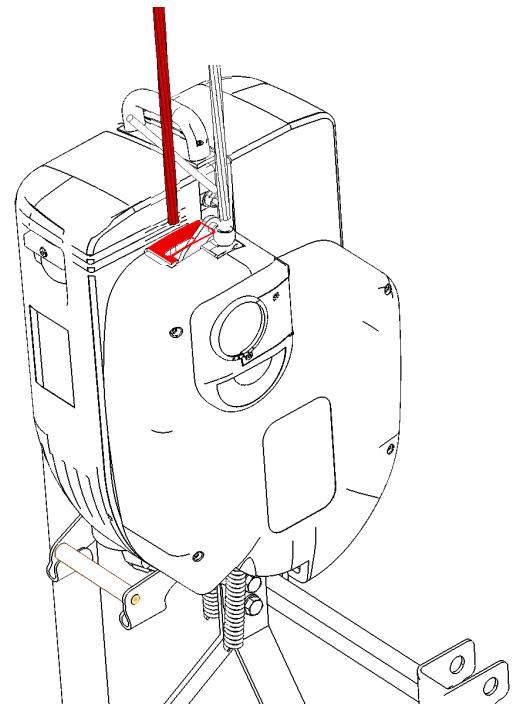

D. Carry out Daily Checklist

Prior to your first ascent to install the Top limit switch striker plates. Always check the suspension system for stability and safety before launching the platform.

E. Install Top Limit Switch Striker Plates

The striker plate activates the top limit switch and must be clamped on the safety wire at a distance of min 20cm from the talurit clamp.

IMPORTANT	Clamp the striker plate to the safety rope ONLY so that the suspension rope passes freely through the slot in the plate.
------------------	---

REMOVING the steel wire rope from the TITAN hoist

Tip: Remove the safety rope first and keep the suspension rope taut, so that the slack rope safety device stays open and allows easy passage of the safety rope.

Safety rope	Manually pull the safety rope out of the slack rope safety device by hand.
Suspension rope	Push the 'down' button on the CCB until the suspension rope no longer comes out of the top of the hoist and pull out the remainder of the rope by hand. <i>Tip: push up on the slack rope lever for easy removal of the suspension rope.</i>

After work is over check that:

- The platform is cleared of tools and equipment.
- All power has been switched off.
- Equipment has been secured where it will not be accessible to be tampered with.

10 Maintenance

ROUTINE MAINTENANCE:

At least every 3 months under normal use, or 50hrs, whichever comes first.

Note: No specialised training is required to perform this basic maintenance.

- 1) Check all plugs socket connections of the hoist and Central Control Box for any signs of water penetration.
- 2) Make a general inspection of hoist for excessive wear and damage.
- 3) Remove main cover and inspect mechanism for any signs of excessive dirt and corrosion. If required, blow out with air or rinse with water.
- 4) Check that traction roller rotates when reeving / de-reeving the steel wire rope through the hoist.
- 5) Check the slack rope safety device for excessive dirt and corrosion. If required, blow out with air or rinse with water. Check that the slack rope lever can move smoothly up and down. If necessary, lubricate with a dry wax-based spray lubricant.
- 6) Replace main cover.
- 7) Carry out the Daily Check List before using the platform.
- 8) Write a maintenance record indicating:
 - Any discrepancies noted and action taken.
 - Hour meter reading of the hoist.

ANNUAL MAINTENANCE:

to be carried out by an authorized service centre or level 3 trained person

- 1) Completely strip the hoist, clean and inspect all parts for wear and damage. Replace worn parts when necessary.
- 2) Clean, lubricate and re-assemble the hoist. Particular attention must be given to the slack rope safety device.
- 3) Place the hoist on a test rig and test that it can lift the rated Working Load Limit.
- 4) Check all plugs socket connections of the hoist and central control box for any signs of water penetration.
- 5) Reinstall the hoist and control box back on the platform and carry out the Daily Check List.
- 6) Write a maintenance record indicating:
 - Repairs carried out and/or parts replaced.
 - Hour meter reading of the hoist.

Special conditions:

The frequency of inspection and maintenance also depends upon the environmental and working conditions:

- When working with abrasive, adhesive or corrosive materials (epoxy, paint, cement, sand blasting, acids, salt water, spraying), the hoist should be protected with a suitable cover and the daily checklist carried out at least once a day.
- Always exercise caution regarding grounding, arcing and insulation, whenever welding or using electrical equipment.

11 Troubleshooting

Problem	Probable cause	Solution
Hoists do not work when pressing the 'up/down' push button. GREEN 'OK' light OFF	No Main power	Check power and see if the power cord is properly plugged and connected or go down using the emergency manual descent
	<i>Three phase hoists only:</i> Phases are reversed	Use screwdriver to reverse phases on the phase reversal power plug of the CCB.
Hoists do not work when pressing the 'up/down' push button. RED warning light ON	Emergency stop button has been depressed	Release emergency stop button
	Both hoists are not connected to the CCB	Check that both hoists are correctly plugged in the CCB
During reeving, the hoist works in the 'up' direction, but the suspension rope does not reeve through	Steel wire rope is not entering the hoist properly	Remove steel wire rope and repeat reeving procedure (refer to Tip under 'Reeving Steel Wire Rope')
Hoists work for just a moment in the "up" direction and then stop. RED warning light ON	The platform is overloaded	Remove excessive load to automatically reset overload
The hoists do not work in the up/down direction RED warning light ON	Top limit switch has been activated	Check for obstruction (E.g. hitting the striker plate). Lower by manual brake release.
Hoist hums, starts slowly or is sluggish, or fails to lift the loaded platform.	Serious voltage drop	Check the power supply and the specifications of the power supply cable
	<i>Single phase hoist only:</i> Start capacitor is defective	Hoist to be checked by an approved service centre
	Service brake failure	Hoist to be checked by an approved service centre
The hoists work for a long time and then stop. The electric motors are hot. RED warning light ON	The thermal protection has been activated	Let the motors cool down to reset automatically. Tip: <i>The 'no power' descent will still operate when the overheating protector is tripped.</i>
The hoist turns both in the 'up' and 'down' direction, but the platform does not come down	The slack rope safety device is activated, and platform has come to rest on an obstruction	Go up to come off the obstruction.
Slack rope lever does not pivot properly	Slack rope mechanism is contaminated by grit or corrosion	Clean and lubricate slack rope safety device
Platform goes up but doesn't go down.	Overspeed safety device is activated.	Immediately stop operating downwards to prevent rope jam. See 12.8 and 12.9
IF PROBLEM PERSISTS, CONTACT YOUR LOCAL SERVICE REPRESENTATIVE.		

12 Safety Features

Automatic slack rope safety device

The automatic slack rope safety device locks mechanically onto the safety rope if the suspension rope loses tension or breaks.

Overload detection device

The overload detection device of each hoist is factory set to stop the 'up' direction of travel if the Working Load Limit (WLL) of the hoist is exceeded by 25%.

The RED warning light on the Central Control Box (CBB) will come ON in case of overload.

The overload detection devices of both hoists are connected in series. If one overload detection device is triggered, then the up movement of both hoists is halted.

To release the overload detection device, remove the excessive load.

***Tip:** In addition to removing the excessive load, it may be required to remove part of the normal load in order to reset the overload detection device. Once the overload detection device is reset, the platform can once again be loaded with the full normal load.*

'No-Power' descent

In the event of a power failure the platform can be lowered at a controlled speed (Approx. 6 m/min.), by pulling the 'No-Power' descent lever on the electro-magnetic service brake.

***Warning:** Never use the emergency manual descent when normal powered movement is possible.*

Top limit switch

The Top limit switch cuts the up movement when it is activated by the striker plate, which is clamped onto the safety rope at the top of travel.

When the Top limit switch is triggered, the platform can be driven down but not up.

The Top limit switches of both hoists are connected in series. If one Top limit switch is activated, then the 'up' movement of both hoists is halted.

Phase Protector (for three phase hoist ONLY)

All three phase Central Control Boxes are fitted with a phase protector, which cuts power supply if phases are reversed. When the phases are correctly connected, the GREEN 'OK' indicator light on the outside of the CBB, AND the GREEN indicator light on the phase protector (only visible when CBB is opened) are ON and the hoists will operate.

If indicator lights are OFF, use a screwdriver to reverse the phases in the phase reversal power plug of the CCB.

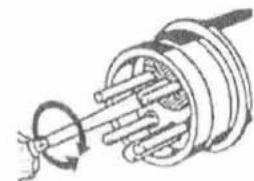

WARNING: DO NOT change any connections in the central control box.

Automatic Levelling System

The central control box is fitted with an automatic levelling system that allows the platform to maintain a stable horizontal position. An out of level condition can occur when one of the hoists is working faster than the other, or if the load in the platform is not evenly distributed.

When the platform is in motion, the automatic levelling system stops the hoist that is going too fast and allows the other hoist to catch up. When both hoists are level again, the levelling system is deactivated and both hoists will function simultaneously.

The automatic levelling system is activated when the platform is out of level by 6°.

The Automatic Levelling System can be tested by using the hoist selector switch to create and out of level condition. Once the platform is out of level, check that the hoist that is too high no longer works in the 'up' direction and the hoist that is too low no longer works in 'down' direction.

Overheating protection for hoist electric motor

The hoist motors are fitted with a thermal contact, which cuts power to the motors in case of overheating.

When the overheating protection is activated, the 'up' movement is halted.

If a hoist motor has overheated, allow it to cool down to continue.

The overheating protectors of both hoists are connected in series. If one overheating protector is triggered, then the 'up' movement of both hoists is halted.

Overspeed Safety device (Mandatory for any BAP 360° platform)

The overspeed safety device locks onto the suspension rope when the suspension rope passes through the hoist (descent speed) at more than 15 m/min. The overspeed safety device can also be triggered manually by pressing the manual release button.

To reset the overspeed safety device, first drive the hoist up a few centimetres and then turn the reset knob clockwise in the direction of the arrow.

Use of Handwheel to reset safety device in case of power failure

If the slack rope safety device or overspeed safety device has been activated and there is no power to the platform, it will be necessary to wind the hoist up a few centimetres manually, to be able to reset the safety device.

1. Pull out main power plug to cut off power supply.
2. Remove plastic plug in the motor cover to expose shaft for the hand wheel.
3. Remove the hand wheel from its storage position and insert shaft into hub.
4. Wind the hoist in the up-direction counter-clockwise ½ turn at the same time as you pull up on the brake lever to open the brake.
5. Release brake lever and repeat.

TIP: *Grab the hand wheel firmly while opening the brake to prevent it from turning and going back down.*

6. The overspeed safety device must be reset manually. The slack rope safety device resets automatically.
7. Put plastic plug back on and return hand wheel to its storage position after use!
8. Plug in main power plug and resume.

13 Steel Wire Specs and Inspection Criteria

When installing the SWR on the wind turbine, always check the complete length of the wires for wear or damages.

Warning: Only use Type 8* Power Climber recommended steel wire ropes!

- The end of the steel wire ropes should be brazed to form a 'bullet' end with a maximum length of 10mm, without loose broken wires.
- Use protective gloves to manipulate the steel wire ropes.



! WARNING !

Steel wires ropes must be replaced in any of the following conditions:

- More than 10 wires are broken on a length of 25cm.
- Excessive corrosion.
- Damage due to heat.
- Reduction of the nominal diameter by more than 10%.
General rejection diameter for type 8* steel wire ropes: 7.5mm.
- Kinking (1), crushing (2), bird caging (3) or any other distortion of the wire rope structure.

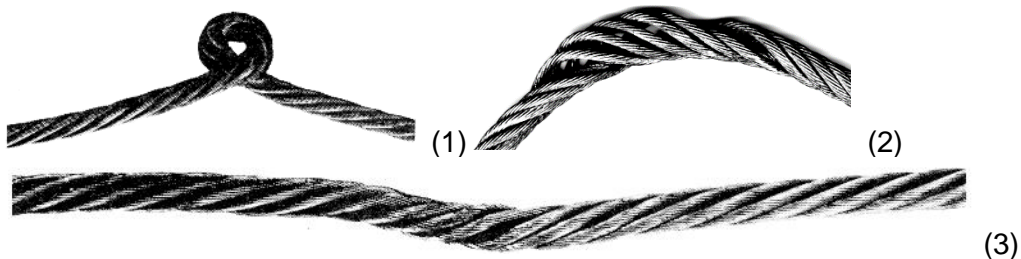

* Type 8 steel wire rope: All steel wire ropes tested and approved by Power Climber for use with Titan hoist

14 General Caution And Precautions

See European Standard EN1808 for details on Applications that are excluded from the EN1808 and other relevant exclusions.

TSP = Temporary Suspended Platform

1. Power Supply to the TSP must be fitted with

- a) Main switch
- b) Residual current device (or earth leakage circuit breaker) of 30 mA
- c) Over current protective device (automatic fuse Type C)

Note: check that the specifications of the electrical supply cable match the power requirement of the platform and will avoid a voltage drop due to cable length.

2. Weather conditions

Temperature range:	-10°C and +55° C
Humidity range:	30 % - 95 %
Contaminants:	Degree of protection IP 54

3. Precautions prior to use

- a) Before using the equipment, operators must carry out the daily checks and make sure that the equipment is in perfect working condition.
- b) Before use, modular TSP equipment must be checked to prevent mixing of inappropriate components.
- c) Before use, check that sufficient space is available for operating the TSP.
- d) Before using the equipment the suspension system must be checked to ensure the stability of the TSP at all times.
- e) In case the area below the TSP is open to the public, preventive measures have to be taken to safeguard the people below (e.g. barriers, roof protected walkways, etc.).
- f) All hazards related to the platform encountering obstructions are not completely covered by the TSP's safety devices. The operator shall check for obstructions along the travel of the platform.
- g) Overload detection device may not protect TSP platforms in all configurations. The operator shall check that the loading of the platform is in accordance with the rated load indicated on the nameplate.
- h) An area must be available to allow operators to get on and off the platform.

4. Precautions during use

- a) The operators must stop working with the equipment and notify the supervisor if faults, damage to the equipment or other circumstances may jeopardize safety.
- b) A suitable communication between the operator and the supervisor is recommended.

5. Suspension System

- a) The platform can be suspended on different types of suspension systems such as roof beams (with counterweights), parapet clamps, davits, fixed suspension points, custom made suspension systems, roof rigs made from tubular scaffolding etc.
- b) Roof systems to be calculated for a max load of W.L.L. x 3 (Maximum allowable stresses below yield.)
- c) Check that roof beams are properly counterweighted (if applicable).
- d) Ensure that the suspension rig is directly above the platform prior to installation.

15 Daily Test

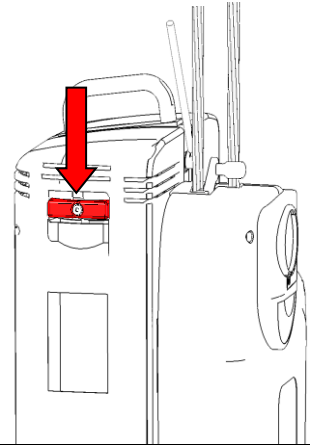
TESTS MUST BE CARRIED OUT EVERY TIME BEFORE USING THE PLATFORM	
1	Visually inspect the platform for damaged, loose or missing parts.
2	Check the suspension system for stability before launching the platform. Check that all counterweights are in place and secured. Check that all steel wire ropes are hooked on properly to the suspension system Check that all SafeFix pins are in place and in lock position. Check that the stirrups are located both on the left and right side on an equal distance from the red indicators.
3	Check that the GREEN ' OK ' indicator light on the CCB is ON .
4	Check that the ' Up/Down ' push buttons and the hoist selector switch are functioning.
5	Push emergency stop button and check that the platform cannot go up or down. (turn button in direction of arrow to reset)
6	Push down on the Top Limit Switch and check that it cuts the 'up' and 'down' direction for both hoists. Repeat procedure for other stirrup. <div style="float: right; text-align: center;">  </div>
↑ Drive the platform 1-2 meters off the ground to continue the tests ↑	
7	a) ON ONE HOIST ONLY, Pull on the ' No Power ' emergency descent lever and check that the hoist can be lowered at a controlled speed. b) Repeat the procedure by manually lowering the other end of the platform. <div style="float: right; text-align: center;">  </div>
8	Run the platform to the top and during travel inspect the steel wire ropes for kinks, broken wires or other damage. Inspect the trailing electrical supply cable for damage. At the top of travel, check that the top limit switch striker plates are correctly fitted and also that the top limit switches are operated by the striker plates.
DO NOT USE EQUIPMENT THAT IS NOT OPERATING PROPERLY	
NEVER OVERRIDE LIMIT SWITCHES OR SAFETY DEVICES	