

**User Manual**

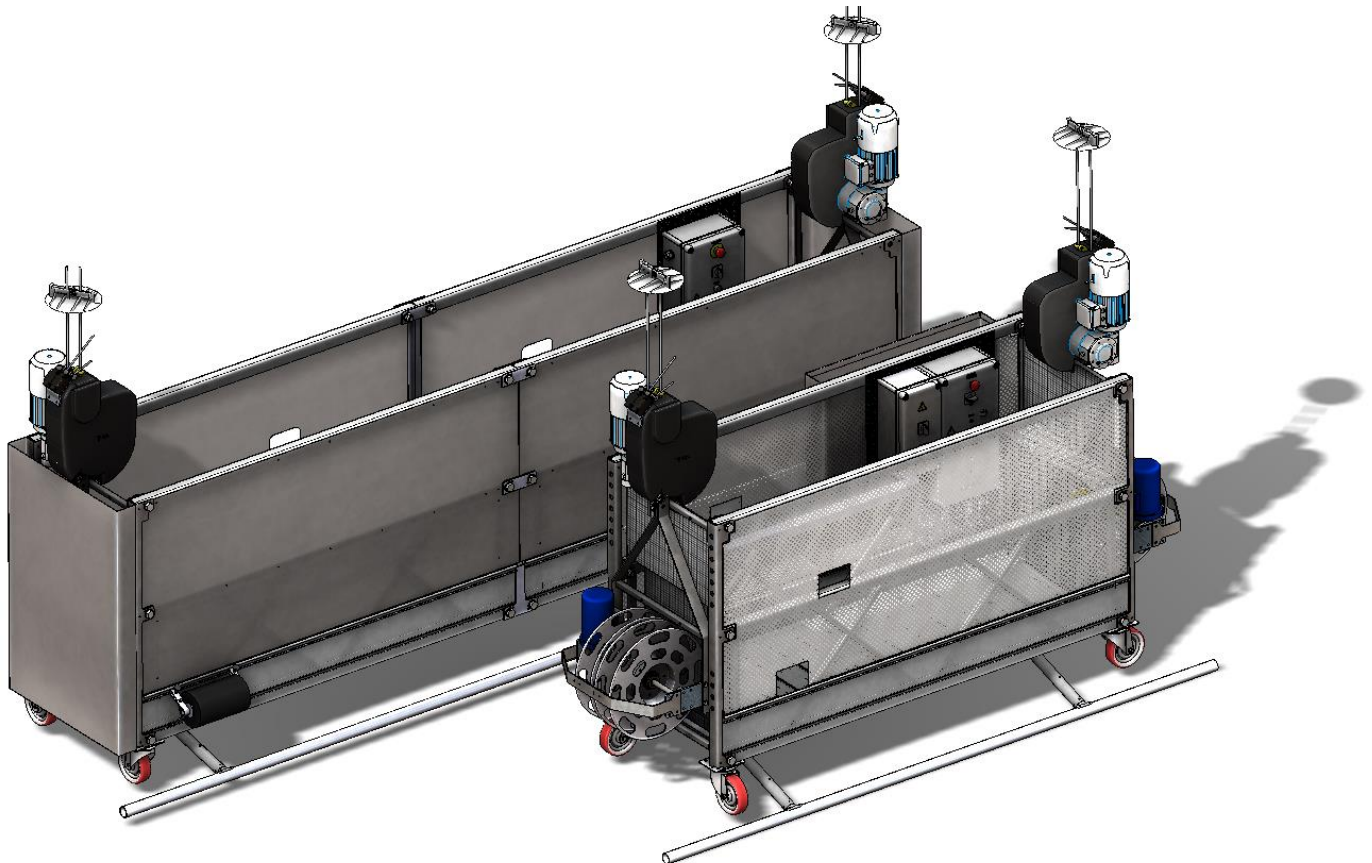

**Modulo PI Platform**  
**Titan - Powered**



In compliance with the Machine Directive 2006/42/EC and according EN1808:2015

This manual should be thoroughly read and understood before start of operations.

Any manoeuvre in conflict with these guidelines is on one's own responsibility.

This manual should be kept close to the platform at all times.

Only use original POWER CLIMBER parts and steel wire ropes.

**Manufacturer**

**Power Climber BVBA**  
**Satenrozen 7**  
**B-2550 Kontich**  
**Belgium**

**[www.PowerClimber.be](http://www.PowerClimber.be)**  
**Tel.: +32-3-451.05.00**  
**Fax: +32-3-451.05.01**  
**E-Mail: [info@PowerClimber.com](mailto:info@PowerClimber.com)**

**Table of Contents**

<b>A.</b>	<b>Revision table.....</b>	<b>2</b>
<b>B.</b>	<b>General description .....</b>	<b>3</b>
<b>C.</b>	<b>General overview .....</b>	<b>4</b>
<b>D.</b>	<b>Titan-PI Hoist.....</b>	<b>5</b>
<b>E.</b>	<b>Operating a Modulo PI Platform.....</b>	<b>7</b>
<b>F.</b>	<b>Safety devices .....</b>	<b>8</b>
<b>G.</b>	<b>Installation .....</b>	<b>12</b>
<b>H.</b>	<b>Checklists .....</b>	<b>14</b>
	<b>Appendix 1: Tests &amp; checks .....</b>	<b>16</b>
	<b>Appendix 2: Risk analysis.....</b>	<b>16</b>
	<b>Appendix 3: Storage and maintenance .....</b>	<b>18</b>
	<b>Appendix 4: Tuning the wire winding couplings.....</b>	<b>20</b>
	<b>Appendix 5: Steel wire rope specifications .....</b>	<b>21</b>
	<b>Appendix 6: Precautions / Limitations .....</b>	<b>22</b>
	<b>Appendix 7: Tuning the Titan overload detection .....</b>	<b>25</b>
	<b>Appendix 8: Troubleshooting .....</b>	<b>26</b>
	<b>Appendix 9: Optional controls.....</b>	<b>28</b>
	<b>Appendix 10: Splitable Modulo PI .....</b>	<b>32</b>

**A. Revision table**

<b>Revision</b>	<b>Date</b>	<b>Reason/modification</b>	<b>Author</b>
A	24/06/2008	Creation	ADM
B	28/10/2015	Added trolley control and appendix.	NV/JDB
C	29/03/2017	WLL depending on platform length	JDB
D	21/04/2021	General update + added all appendices	RDB

## **B. General description**

The purpose of a Modulo PI Platform is to move people and their equipment upward or downward for maintenance and inspection of buildings or structures.

The platform can be used inside as well as on the outside wall of a building. Every Modulo PI Platform is designed for a specific building and will stay in or on this building at all times.

The Modulo PI Platform is made up of two aluminium side-structures (sideframes), an aluminium floor panel and two guardrails. These are mounted between two steel stirrups on which Titan hoists are mounted.

The suspension and safety steel wire ropes are wound up using the wire winders.

The Titan hoists are operated by a central control box, mounted in the platform.

The Modulo PI platform is highly customizable. Custom lengths and a great variety of options are available to suit each application.

The optional 'splittable' platform allows the platform to be split into several sections.

Assembling the platform using different combinations of these sections result in several configurations of the Modulo PI platform. See "**Appendix 10: Splittable Modulo PI**" for more information.

General information regarding each particular Modulo PI platform can be found on the nameplate of the platform and its hoists.

**C. General overview<sup>1</sup>**

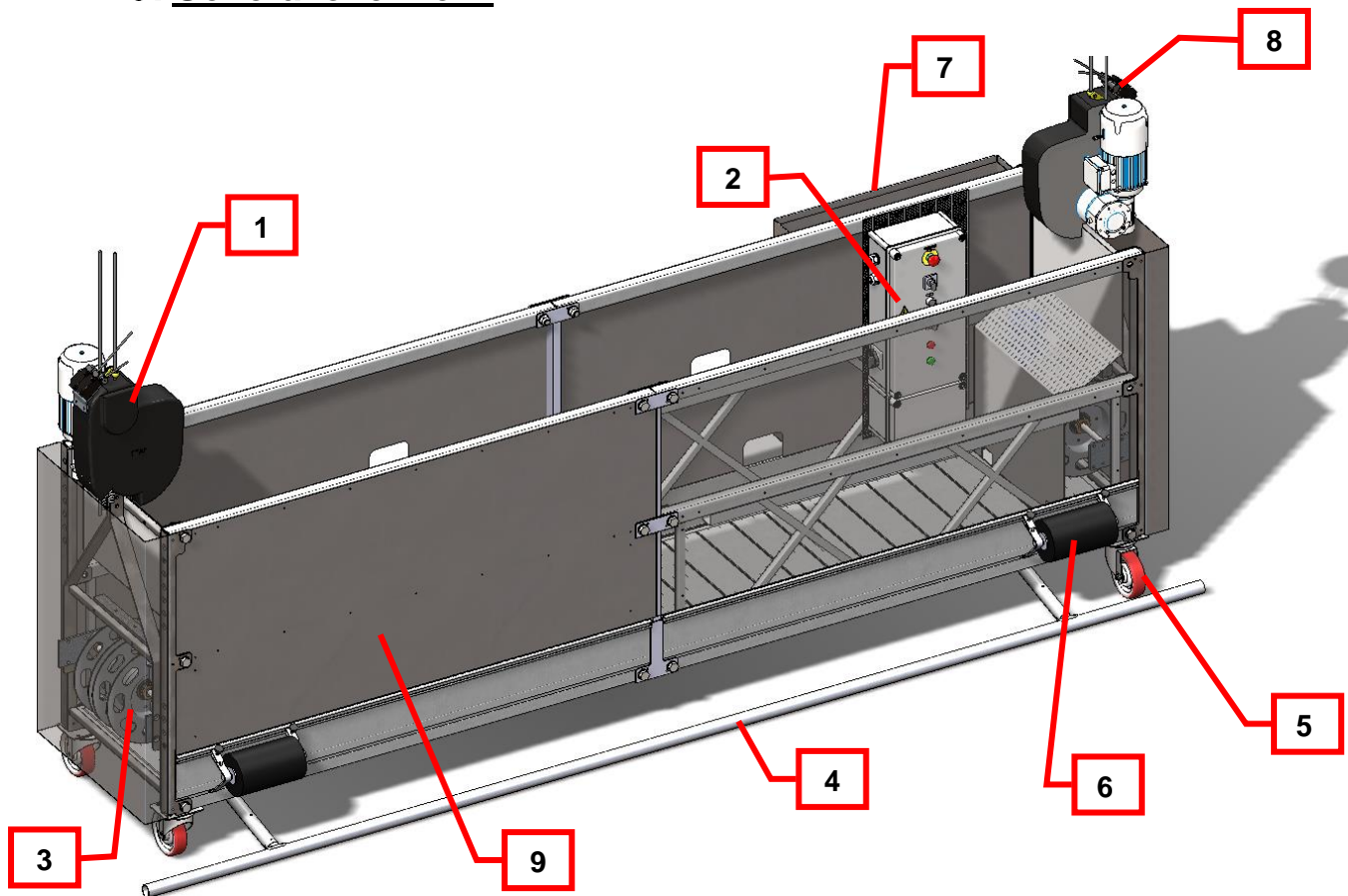

- 1) Titan-PI hoist with slack rope, overload and optional overspeed safety devices
- 2) Central control box
- 3) Motorized twin drum wire winders
- 4) Bottom trip bar / bottom obstruction bar
- 5) Castor wheels (or landing buffers)
- 6) Soft wall rollers
- 7) Storage bin for supply cable (optional)
- 8) Top limit & ultimate top limit switches
- 9) Anodized aluminium cladding

<sup>1</sup> The platform above is a representation of a Modulo PI platform with common features and options. The actual platform may vary from the above, depending on the application's requirements and chosen options.

## D. Titan-PI Hoist

### D.1. Overview

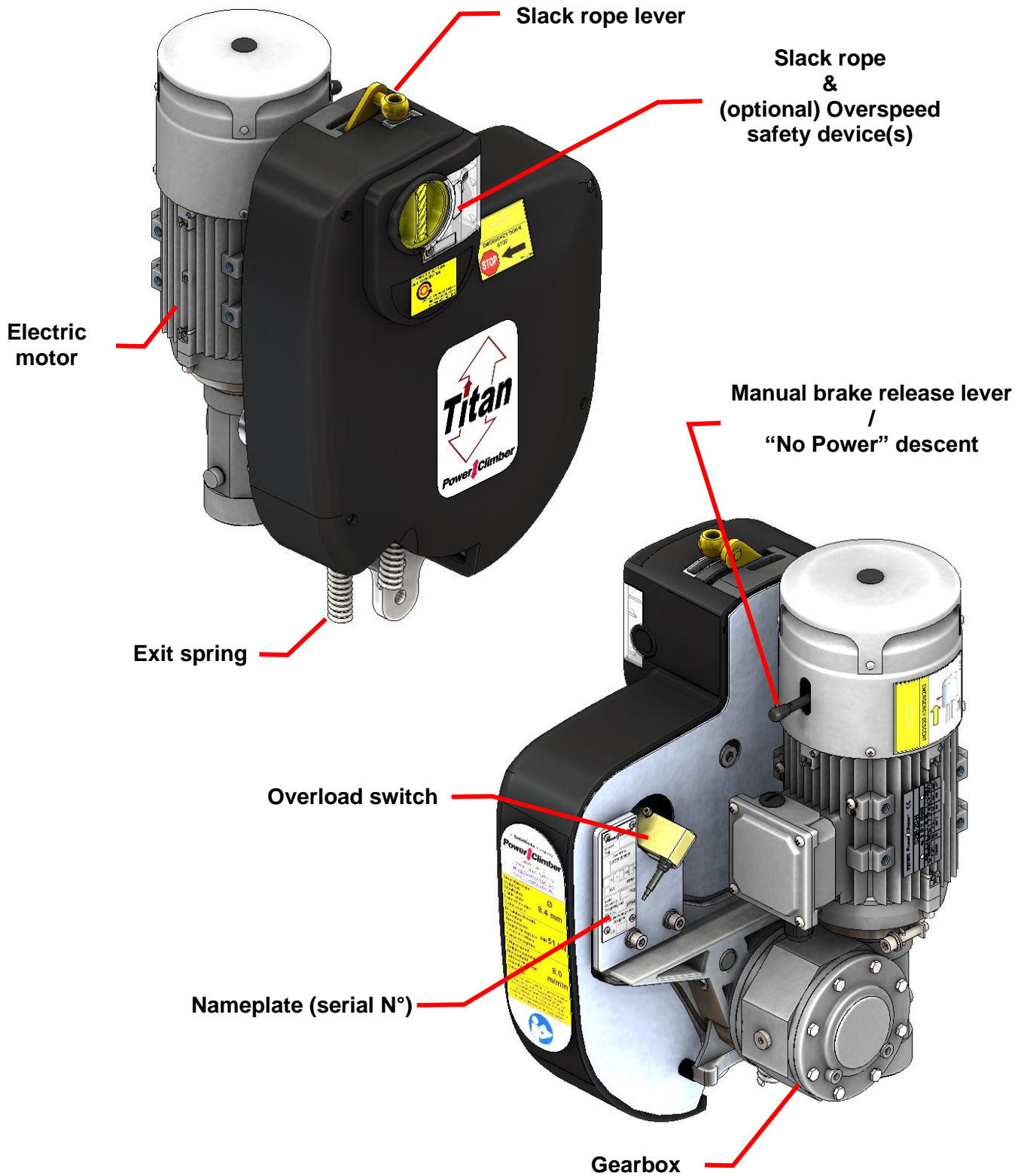

**D.2. Specifications**

Depending on the platform’s length, self-weight, rated load, lifting height, etc..., hoists of different lifting capacities are used for Modulo PI Platforms. Check the “WLL Range” on the hoist’s nameplate to see which type is mounted on that particular Modulo PI platform.

**Warning:** *Never interchange hoists of different Modulo PI platforms!*

<b>Titan-PI (Three Phase)</b>						
<b>Power Supply</b>		3 x 400V (+N) +E , 50Hz *				
<b>W.L.L. Range (kg)</b>		150-250	250-350	350-450	450-550	550-650
<b>Motor Power (kW)</b>		0.45	0.6	0.7	0.9	0.9
<b>Current at max. WLL</b>	<b>Run (A)</b>	2	2.5	3	3.3	3.5
	<b>Start (A)</b>	6	7.5	9	9.9	10.5
<b>Wire rope type</b>		Type 8 **				
<b>Hoisting speed</b>		approx. 8 m/min				
<b>Noise Level</b>		< 80 dBA				
<b>IP-rating</b>		IP 54				
<b>Self-weight</b>		36 kg				

<b>Titan-PI (Single Phase)</b>		
<b>Power Supply</b>		1 x 230V +E , 50Hz *
<b>W.L.L. Range (kg)</b>		275-400
<b>Motor Power (kW)</b>		0.55
<b>Current at max. WLL</b>	<b>Run (A)</b>	3.7
	<b>Start (A)</b>	14.8
<b>Wire rope type</b>		Type 8**
<b>Hoisting speed</b>		approx. 8 m/min
<b>Noise Level</b>		< 80 dBA
<b>IP-rating</b>		IP 54
<b>Self-weight</b>		36 kg

\* Other voltages and frequencies available. Contact manufacturer for specifications.  
 \*\* Type 8 steel wire rope: All steel wire ropes tested and approved by Power Climber for use with Titan hoist.

## **E. Operating a Modulo PI Platform**

The Modulo PI platform and all its components are being controlled by a Central Control Box (CCB).

The standard controls can be expanded with extra options. See “**Appendix 9: Optional controls**” for extra information.

Due to restrictions of the application, the layout of the control box and its buttons may vary from the standard shown below. Always verify the name/symbols on the buttons to make sure the wanted operation is chosen.

### **E.1. Basic platform control**

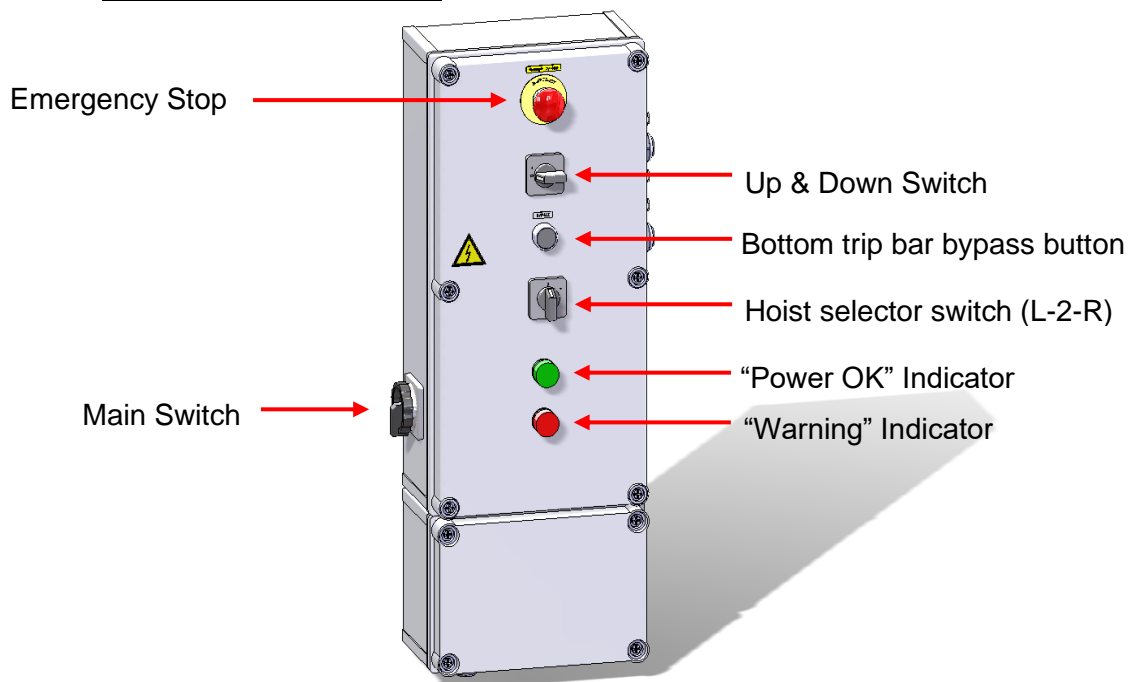

**Main Switch:** Turn on the main switch to power up the CCB. It can be locked in the “off”-position using a padlock (padlock not included).

**Up & Down Switch:** Hold-to-run switch to operate the platform up- or downward.

**Hoist Selector Switch:** Allows for individual hoist operation for reeving and de-reeving the steel wire ropes or restoring the platform’s inclination manually.  
(Left hoist only – Both hoists – Right hoist only)

**Green “Power OK” Indicator:** Lights up when the following conditions are met:

- Supply cable is connected correctly.
- Main switch is on.
- Voltage and phase sequence (in case of a 3-phase power supply) are correct.

**Red “Warning” Indicator:** Lights up when there’s a fault or when a safety device has been triggered. It lights up in the following cases:

- One or both hoists aren’t plugged in.
- The emergency stop has been activated.
- The platform is in an overload condition.
- An ultimate top limit switch is triggered.
- One of the hoist’s thermal protection has triggered.

## F. Safety devices

### F.1. Slack rope safety device

The slack rope safety device contains a spring-loaded eye through which the suspension rope is reeved. The device will lock onto the safety rope if one of the following situations occurs:

- The suspension rope loses tension or breaks.
- One hoist keeps on descending (e.g.: Brake of motor is slipping).  
When a certain inclination is reached (max. 14°), the slack rope safety device will mechanically prevent the hoist from lowering further.

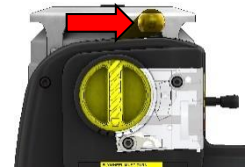

### F.2. Overspeed safety device

The overspeed safety device acts on the suspension steel wire rope and is set to trigger at approximately 15m/min.

The overspeed safety device is triggered by an overspeed governor (flywheel) which is being driven by the suspension wire rope running through the hoist. The rotation of the flywheel can be checked through the inspection window during travel.

The overspeed limiter can be activated manually by pressing the black button on the side of the overspeed assembly.

To reset the overspeed safety device, the hoist should be operated upward a couple of centimetres to unload the activated overspeed device. The overspeed device can then be reset by turning the yellow reset knob clockwise till it locks into its vertical position.



When the over speed limiter is active and the power is down simultaneously, the hoist must be brought up manually to be able to reset the overspeed safety device. The provided handwheel should be used in this case. Follow the hereafter mentioned steps:

- a. Turn off the main switch and unplug the power supply plug.
- b. Remove the rubber grommet from the cover at the top of the hoist's motor.
- c. Locate the handwheel and insert it in the hole at the top of the motor.
- d. Turn the hand wheel counterclockwise while lifting the brake lever to open the brake.  
**Important:** Hold the hand wheel firmly while opening the brake to prevent further lowering
- e. Release the brake lever before letting go of the handwheel.
- f. Repeat steps 3 & 4 until the yellow reset knob can be turned clockwise in its vertical position.
- g. If power can't be restored in time, the platform can now be lowered manually by pulling up the brake lever.
- h. After use, place the rubber grommet back in the hoist's motor cover and put the hand wheel back in its storage place.

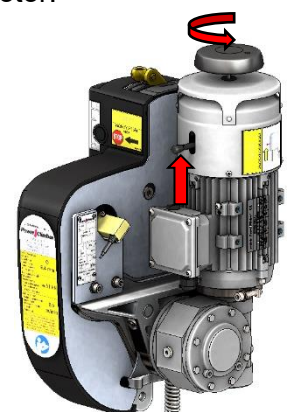



### F.3. Top limit switch

The top limit switch is activated by the striker plate, which is clamped at the top of the safety rope.

When one of the top limit switches is triggered, upward movement of both hoists will be disabled. Downward movement will still be possible.

### F.4. Ultimate top limit switch

The ultimate top limit switch is activated when the normal top limit switch fails.

When one of the switches triggered, both the up- and downward movement of both hoists will be disabled. The red warning light will light up. The top limit switch should be checked for correct functioning and/or finetuned so it triggers before the ultimate top limit switch does.

### F.5. Overload detection system

Both hoists are equipped with an overload detection system that is set by default to a weight of 125% of the rated load of the platform.

Once the overload detection system of one of the hoists has been activated, both the up- and the downward movement of both hoists will be disabled. The red warning light will light up.

In order to automatically reset the overload detection system, the excessive load must be removed.

*Tip: It is possible that removing the excessive load is not sufficient. It might be that a part of the rated load must be removed before the overload detection system resets. When the overload detection system is reset, the platform can be loaded with the full normal load again.*

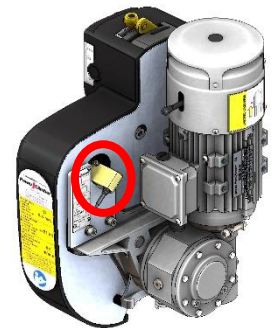

### F.6. 'No power' descent

In the event of a power failure, the platform can be lowered at a controlled speed (approximately 6 m/min) by pulling the lever of the electro-magnetic brake.

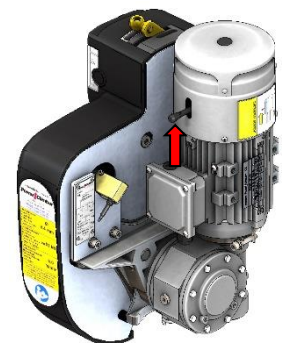

### F.7. Bottom trip bar

The bottom trip bar is mounted underneath the platform. It interrupts the downward movement of both hoists when the platform hits an obstacle. Upward movement is still possible.

*Tip: In order to further lower the platform to land or in order to de-reeve the hoists, the bypass button and the downward movement should be operated simultaneously.*

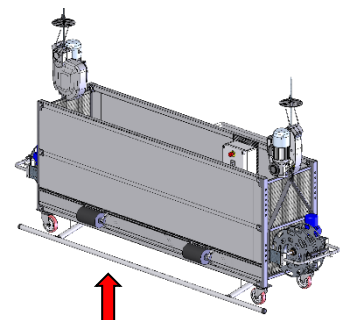

### F.8. Phase protection (only three phase systems)

All platforms supplied by a three-phase power supply, have a phase protection which can be found on the inside of the central control box, labelled “K8”.

Both the green and the red light on the phase protector should be lit to be able to operate the platform.

If not, use the following diagram to troubleshoot:

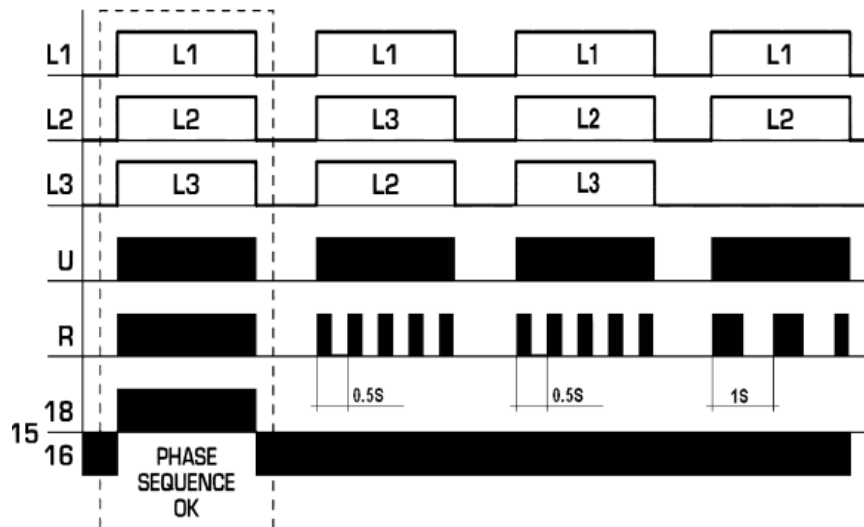

- Red LED is flashing with an interval of 0.5s: wrong phase sequence. Switch two phases of the power supply.  
**Warning:** Never change a connection in the central control box.
- Red LED is flashing with an interval of 1: phase failure. Check the power supply.

### F.9. Automatic levelling system

Each Modulo PI platform is equipped with an automatic levelling system. An out of level condition may occur when one hoist works faster than the other or when the weight of the platform is not equally distributed.

When the platform’s inclination reaches approximately 6 degrees, the automatic levelling system will interrupt the movement of one hoist, so the other hoist can catch up. When both hoists are put equal again, the interrupted hoist will restart automatically.

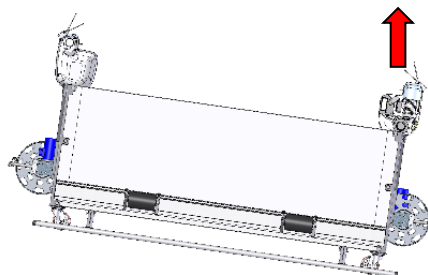

**F.10. Thermal protection for the hoist's motors**

The hoist's motors have a thermal protection, which cuts power to the hoist in case of overheating and halts movement in both the up- and downward direction. When the hoist's motor gets overheated, give it time to cool down. The overheat protection of both hoists are placed serially. If one of the overheat protections is activated, the power supply to both hoists is cut. The red warning light will light up.

**F.11. Thermal protection for the wire winder's motors**

In the central control panel, there is a thermo-magnetic relay that protects the motor of the wire winders. In that case, the upward movement of the hoists is cut as well.

## **G. Installation**

Each Modulo PI platform is suspended and fully tested by Power Climber before shipping.

1. Unpack the platform and examine on any transportation damage.
2. Place the platform underneath the suspension system. Check if the distance between the suspension points on the suspension system is equal to the distance between the suspension points on the platform (CD: Center distance).
3. Secure the male power supply plug into the power socket and turn on the main switch on the central control box.

**Important:** *The power supply must be secured with an earth leakage circuit breaker (ELCB) of 30 mA and an automatic fuse of 16 A (type C). Make sure the electrical extension cords are dimensioned properly to prevent a voltage drop.*

**Note:** *All three phase platforms are equipped with phase protection and will not work if not all phases are connected correctly. For further information see “Appendix 8: Troubleshooting”.*

4. Make sure the hoists and wire winders work when the UP button is being operated. The top of the wire winder drums must rotate towards the hoist.
5. Make sure that only the hoists work when the DOWN button is being operated (no operation of the wire winders).
6. If the supply cable comes from the top: attach the supply cable to the suspension system using the cable retainer.
7. Make sure the steel wire ropes are long enough.  
**Important:** *Required length of the steel wire rope = height of the building + 5 m.*
8. Unwind the **safety** steel wire ropes and put them on the roof. Attach the steel wire ropes to the suspension system using the safety hooks and lower them to the ground. Reeve the safety steel wire ropes, see “**Reeving the steel wire ropes**”.
9. Unwind the **suspension** steel wire ropes and put them on the roof. Attach the steel wire ropes to the suspension system using the safety hooks and lower them to the ground. Reeve the suspension steel wire rope, see “**Reeving the steel wire ropes**”.  
**Tip:** *Prevent the steel wire ropes from becoming entangled by reeving the safety and the suspension steel wire ropes separately.*
10. Next, carry out all the actions as described in “**Appendix 1: Tests & checks**”.
11. After successfully performing all tests, the first ride to the top can be made to attach the striker plates.  
**Important:** *Clamp the striker plate to the safety wire rope, the suspension wire rope should be allowed to move freely.*

## G.1. Reeving the steel wire ropes

**Important:** Always reeve the safety rope first before reeving the suspension rope.

### Safety rope

1. Put the slack rope lever in its upright position to open the clamps of the slack rope safety device and push the safety steel wire rope through the slot next to the slack rope eye.
2. Put the tail end of the safety rope through the hole in the wire winder.
3. Operate upward in order to tighten the steel wire rope.

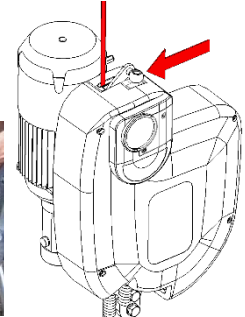

### Suspension rope

1. Put the slack rope lever in its upright position and put the steel wire rope through the eye of the slack rope lever. Push until you experience resistance.
2. Select the correct hoist and operate upward to allow the steel wire rope to move through the hoist. The tail end of the steel wire rope will come out at the bottom of the hoist.
3. Repeat step 2 and 3 of the safety steel wire rope to load the suspension steel wire rope on the wire winder.

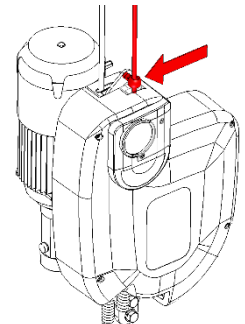

**Tip:** If there are problems with reeving the suspension steel wire rope, you can bend the tail end of the steel wire rope a little before putting the steel wire rope in the hoist.

## G.2. De-reeving the steel wire ropes

**Tip:** Always de-reeve the safety steel wire ropes first and keep the suspension steel wire rope tight so the slack rope safety device stays open and the safety steel wire rope can easily be removed.

### Safety rope

Unwind the wire winder drum manually while pulling the safety rope out of the top of the hoist.

### Suspension rope

**Important:** The bottom trip bar must be bypassed manually in order to be able to de-reeve the suspension steel wire rope.

Operate the hoist downward while pushing the bypass button. Meanwhile, the steel wire rope may need some help de-reeving by pulling it slightly out of the top of the hoist. Keep going until the suspension steel wire rope no longer comes out of the hoist at the top. Then, pull out the rest of the steel wire rope by hand.

**Tip:** If the hoist contains an overspeed safety device, hold the yellow overspeed reset knob vertically while pulling the last bit of the steel wire rope out by hand. This prevents the overspeed from triggering.

## H. Checklists

### H.1. Daily Checklist

**Important:** The following tests must be performed before the start of each operation of the Modulo PI.

**Important:** Inspect the platform visually to detect damage, loose or missing parts before beginning with the check list.

#### a. Check if the main platform controls function as intended

- 'Power OK' indicator lights up
- 'UP' and 'DOWN' buttons function correctly
- Hoist selector switch works correctly
- Check whether the hoists and the winding drums work properly when pushing the 'UP' button. The top of the winding drums must turn towards the hoist.  
The wire winders are not electrically powered when pushing the 'DOWN' button.



#### b. Bottom trip bar

Raise the bottom trip bar. Check if the downward movement has been cut. Push the bypass button to check if the platform can move downward again.

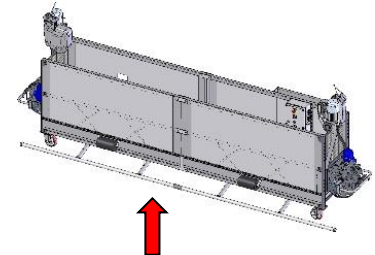

#### c. Emergency stop

Push the emergency stop on the central control panel and check whether the up and downward movement of the platform are disabled.  
To undo action, turn the button in the direction indicated by the arrow on the button.

#### d. Top limit and Ultimate Top limit switch

Push down the lever of a top limit switch (highest one) and check whether the platform can no longer move upward. Downward movement should still be enabled.

Push down the lever of an emergency/ultimate top limit switch. Make sure both the up- and downward movement of the platform are disabled.

Repeat this procedure for the other side.

Move the platform to 1-2 metres above the ground to perform the following tests.

**a. 'No power' descent and slack rope safety device**

Pull up the brake lever on one hoist and check if the hoist can be lowered at a controlled speed.

Continue pushing and make sure the slack rope safety device activates before 14 degrees of inclination. This mechanical safety device will prevent the platform from sloping any further.

Repeat the procedure by manually lowering the other side.

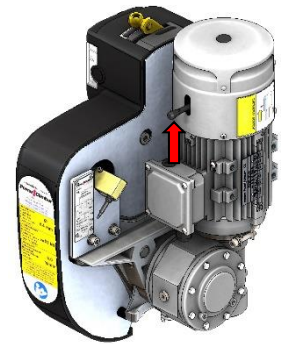

**b. Overspeed safety device (optional)**

The overspeed limiter can be activated manually by pressing the black button on the side of the overspeed assembly. Lower the platform manually by pulling up the brake lever to make sure the overspeed device prevents the platform from lowering.

To reset the overspeed safety device, the hoist should be operated upward a couple of centimetres to unload the activated overspeed device. The overspeed device can then be reset by turning the yellow reset knob clockwise till it locks into its vertical position.

Repeat the procedure for the other side.



**c. Steel wire rope and power supply cable**

Move the platform all the way to the top. Along the way inspect the safety and the suspension steel wire ropes for kinks, broken wires or other damage.

At the same time, check the power supply cable for damage.

**Important:** In everyday use, always be mindful of possible damage of steel wire ropes or the supply cable. Handle with care. See '**Appendix 5: Steel wire rope specifications**' for further details on the steel wire ropes.

## **H.2. Checklist after use**

1. Turn off the main switch on the central control panel. Lock if necessary.
2. Disengage the supply cable.
3. If the platform is not used for a longer period, it should be stored.

See "**Appendix 3: Storage and maintenance**" for more details.

## **Appendix 1: Tests & checks**

The following tests and checks should be performed at the first installation and every single time the situation has altered significantly (for example after a change to another suspension system or after hoist maintenance). These tests should always be followed by the tests described in the “**Daily Checklist**” before the platform is released for use.

### **Automatic Levelling system**

- a. Bring the platform up to a height of approx. 3m.
- b. Turn the hoist selector switch to ‘L’ (left) and let the platform come down until the automatic levelling system is activated (approx. 6°) and the platform stops.
- c. Turn the hoist selector switch to ‘2’ (both) and let the platform come down.
- d. Only the right hoist will work. The left hoist will only start working when the platform has reached its horizontal position again.
- e. Repeat this process with the ‘R’ (right) hoist.

### **Wire winding drums**

Check the friction coupling and check if the tabs on the lock washer of the friction coupling is bent to lock the adjustment nut. See “**Appendix 4: Tuning the wire winding couplings**” for more information.

### **Load test**

#### **Platform**

Lift the platform to about 50 cm high; load the test weight onto the platform until 150% of the rated safe working load of the platform is reached. Check if the structure of the platform suffers deformation in any way.

#### **Suspension system**

Place a load on each suspension point of 2,5 times the nominal capacity of a hoist. This load may never be carried by the platform. Leave this weight hanging for about 15 minutes. Check if the suspension system suffers deformation or if there are cracks in the welds.

### **Striker plate**

Check if the striker plates are installed correctly and if the end switches are activated by this plate.

### **Overload detection system**

The overload detection system is set at our factory to stop the up and down movement when 125% of the rated load is reached.

This can be tested if necessary, by putting a test weight on the platform according to EN1808:2015 location-wise.

### **Local security regulations**

Check if the local security regulations require you to perform additional tests.

### **Transfer of the platform**

After all the tests have been passed, on the platform as well as on the suspension system, the installation can be handed over to the customer.

### **User training**

Arrangements should be made for the user training on the platform. These users should also have sufficient know-how to perform the daily checks and understand the safety devices.



**Appendix 2: Risk analysis**

	<b>HAZARD</b>		<b>SAFETY ACTION</b>		<b>RESULT</b>
1.	Breaking of suspension wire	→	Suspension wire becomes slack: slack rope safety device activates	→	Slack rope safety device grabs onto the safety wire and holds the platform
2.	Inclination of the platform (electrically)	→	Electronic tilting switch is activated at around 6°	→	Platform levels automatically by pushing up or down
3.	Inclination of the platform (mechanically) / Slowly creeping down	→	Slack rope safety device is activated before 14°	→	Slack rope safety device grabs onto the safety wire and holds the platform
4.	Overspeed condition of a hoist (with overspeed safety device)	→	Overspeed safety device activates	→	Overspeed safety device grabs onto the suspension wire and holds the platform
5.	Overspeed condition of a hoist (without overspeed safety device)	→	Platform will become inclined and the slack rope safety device is activated	→	Slack rope safety device grabs onto the safety wire and holds the platform
6.	Overload condition or the platform hooks under a rigid or heavy object	→	Overload detection device is activated	→	Platform will be stopped. Up and down direction is cut off
7.	Platform hits an object, or reaches ground level	→	Bottom limit trip bar is activated	→	Platform will be stopped Down direction is cut off
8.	Platform has reached top position.	→	Top limit switch is activated by striker plate	→	Platform will be stopped Up direction is cut off
9.	Failure of top limit switch	→	Ultimate top limit is activated by striker plate	→	Platform will be stopped Up and down direction is cut off
12.	Power failure	→	Release service brake manually by pulling the emergency descent lever	→	Platform will move down at a lower speed than the normal downward speed

## Appendix 3: Storage and maintenance

### Storage

- The platform should be stored in a covered parking place where the necessary maintenance can be performed.
- The platform must be locked and cannot be accessible for unauthorized persons.
- If no covered place is available, the platform should be covered watertight when not in use.
- Platforms that are used outside, on places that are subject to high wind speeds (hurricanes or typhoons), should be fastened safely, when not in use.

### Maintenance

#### Routine maintenance

- At least every 3 months under normal use, or
- 50 operating hours, whichever comes first (hour meter can be found in the central control box).

**Note:** *No specialized training is required to perform this basic maintenance.*

- 1) Check all plugs and socket connections of the hoist and central control box for any signs of water penetration, visual damage or loose wires / glands.
- 2) Make a general inspection of platform and hoist for excessive wear and damage.
- 3) Remove the hoist's main cover and inspect mechanism for any signs of excessive dirt and corrosion. If required, blow out with air or rinse with water.
- 4) Check that traction roller rotates when reeving / de-reeving the steel wire rope through the hoist.
- 5) Check the slack rope safety device for excessive dirt and corrosion. If required, blow out with air or rinse with water. Check that the slack rope lever can move smoothly up and down. If necessary, lubricate lightly with a dry wax-based spray lubricant.
- 6) If applicable, check the optional overspeed safety device for excessive dirt and corrosion. Check that the overspeed governor can rotate freely. Check that the centrifugal masses can move freely and that the springs aren't corroded or damaged. Check if the overspeed safety device triggers properly by pressing the black manual release button.  
If necessary, lubricate lightly with a dry wax-based spray lubricant.
- 7) Re-install main cover.
- 8) Carry out the "**Daily Checklist**" before using the platform.
- 9) Write a maintenance record indicating:
  - Any discrepancies noted and action taken.
  - Hour meter reading of the hoist (if integrated by Power Climber: hour meter can be found in the Central Control Box).

### **Annual Maintenance**

**Warning:** *To be carried out annually by an authorized service centre.*

- 1) Completely strip the hoist, clean and inspect all parts for wear and damage. Replace worn parts when necessary.
- 2) Clean, lubricate and re-assemble the hoist. Particular attention must be given to the slack rope and the optional overspeed safety device.
- 3) Check all plugs and socket connections of the hoist and central control box for any signs of water penetration, visual damage or loose wires / glands.
- 4) Reinstall the hoist on the platform and carry out the test found in “**Appendix 1: Tests & checks**”.
- 5) Write a maintenance record indicating:
  - Repairs carried out and/or parts replaced.
  - Hour meter reading of the hoist (if integrated by Power Climber: hour meter can be found in the Central Control Box).

### **Special Conditions**

The frequency of inspection and maintenance also depends on the environment and the working conditions:

- When working with abrasive, adhesive or corrosive materials (epoxy, paint, cement, sand blasting, acids, salt water, spraying,...), the hoist should be protected with a suitable cover and the daily checklist carried out at least once a day.
- Always exercise caution regarding grounding, arcing and insulation, whenever welding or using electrical equipment.

## **Appendix 4: Tuning the wire winding couplings**

The motor of the wire winder drums only runs when the platform moves upward. When the platform moves downward, the steel wire rope is simply pulled from the winding drum. The drums can rotate relative to the axle because of its friction clutch.

Every winding drum is equipped with a friction coupling, which must be set so the winding drum firmly winds up the steel wire rope.

### **Procedure to tune the clutch:**

1. Open the tabs of the lock washer.
2. Unscrew the nut with a special 50 mm nut spanner (included)
3. Tighten the nut manually (turn until it makes contact with the lock washer)
4. Turn the nut  $\frac{1}{4}$  turn further with the nut spanner.
5. Check the adjustment by manually turning the drum ensuring it is possible to turn the drum with a force of approximately 12-15 kg on the outer edge of the wire winder drum.
6. Close the tabs of the lock washer.

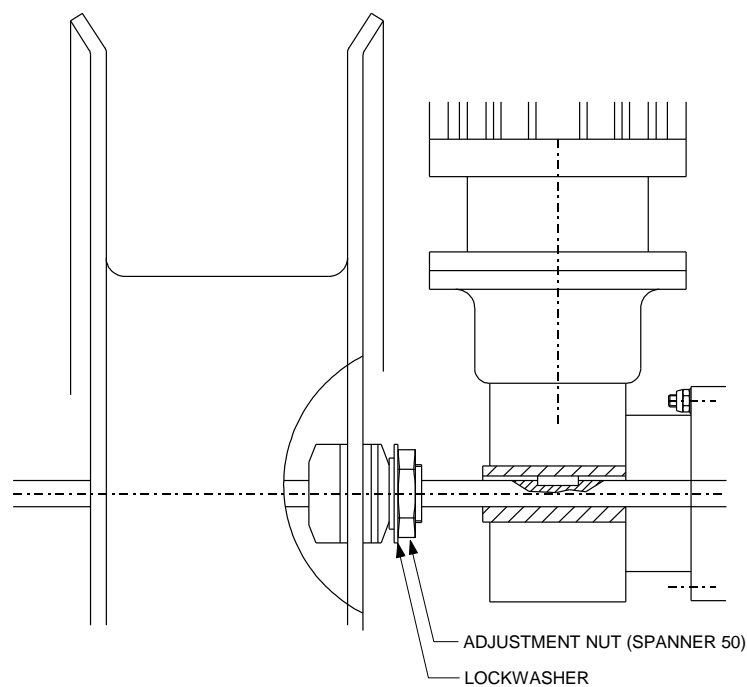

## Appendix 5: Steel wire rope specifications

**Warning:** Only use Type 8\* Power Climber recommended steel wire ropes!

- The end of the steel wire ropes should be brazed to form a 'bullet' end with a maximum length of 10mm, without loose or broken wires.



- Use protective gloves to manipulate the steel wire ropes.

### **! WARNING !**

**Steel wires ropes must be replaced in any of the following conditions:**

- More than 10 wires are broken on a length of 25cm.
- Excessive corrosion.
- Damage due to heat.
- Reduction of the nominal diameter by more than 10%.  
General rejection diameter for type 8\* steel wire ropes: 7.5mm.
- Kinking (1), crushing (2), bird caging (3) or any other distortion of the wire rope structure.

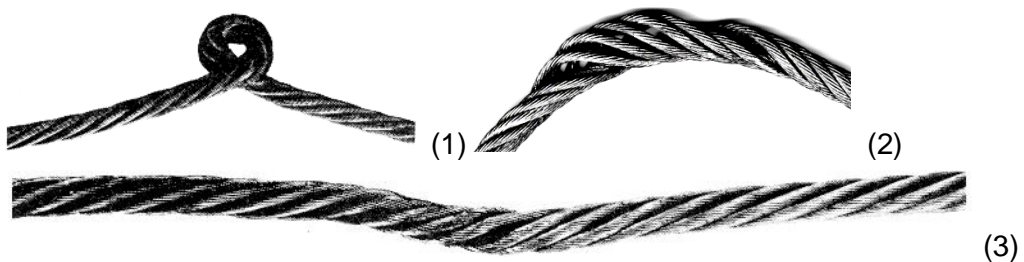

\* Type 8 steel wire rope: All steel wire ropes tested and approved by Power Climber for use with Titan hoist

## **Appendix 6: Precautions / Limitations**

### **Warning**

- Only authorised, fully qualified and physically fit personnel can operate the hoists.
- Before use, the manual should be thoroughly read and understood.
- Users may sustain serious injury when instructions are not followed correctly.

**SAE:** Suspended Access Equipment

**BMU:** Building Maintenance Unit

**TSP:** Temporary Suspended Platform

**PI:** Permanent Installation

### **1. Exclusion of the European Standard EN1808**

Following points are not covered:

- a. Working in extreme circumstances (e.g. extreme weather conditions, corrosive environment, strong magnetic field, etc.).
- b. Working under specific regulations (e.g. potential explosive atmosphere, working with lifelines).
- c. Passenger transport from one level to another.
- d. Transport of hazardous substances (e.g. liquid metal, acids/bases, radioactive material, fragile material).
- e. Hazards occurring when handling suspending loads in conjunction with the suspended platform.
- f. Risks involved in using on the public high way, above water or in places where it is impossible to lower to a safe position.
- g. Risks involved in using at high wind speeds that would push around a load of more than 2 m<sup>2</sup>.
- h. Hoists with cableless control systems.

### **2. Applications for suspension bridge installations that are not covered by the European EN1808.**

- a. Access to working areas with an inclination in excess of 45° compared to vertical.
- b. Suspended platforms attached to cranes.
- c. Suspension installations for access to silos.
- d. Applications in which fibre cable or chains are used to hoist suspension platforms.
- e. Suspension installations used underground.
- f. Suspension installations driven by a combustion engine.
- g. Suspension installation for use in shafts.

### **3. Power supply**

- a. A main switch should be put in front of the power supply.
- b. The power supply must be secured with a residual current device (Earth Leakage Current Breaker) of 30 mA and an automatic (overcurrent) fuse of 16 A (type C).

**4. Weather conditions**

- a. When using in windswept regions and at a hoist altitude above 40 m, the freedom of movement of the application with regard to the building should be limited. To that end, a safety line is installed between the application and the building.
- b. Physical, environmental and working conditions of electrical material:

Temperature limits	Between -10°C and +55° C
Humidity limits	Between 30 % and 95 %
Elevation above sea level	Up to 1200 m
Max wind speed	12.5m/s
Pollution	Protection degree IP54

- c. Do not use the installation during storms.

**5. Precautions before use**

- a. The rescue and evacuation procedure for the suspended platform should be considered and embedded in the total rescue and evacuation procedure of the "site".
- b. Before using the installation, the operators should perform the daily checks and tests to make sure the material is in perfect condition.
- c. Before use, the suspension system should always be checked to ensure the stability of the application.
- d. If the application hangs above a public place, security measures must be taken (e.g. traffic diversion, covered passageway, etc.).
- e. All risks involved in a possible obstruction of the platform and the lowering route are not described in the safety regulations. The operator should detect any obstructions during the installation run.
- f. Sufficient space should be provided where the operators get in and out of the installation.

**6. Measures during use**

- a. The operators must stop the platform and inform their superior when damage is detected or if the circumstances are no longer safe to operate the application.
- b. There should be sufficient communication between the operators and their superior.

**7. Out of service**

When the work is done, the operator must set the platform to 'out of service', shut down the application and cut off the power supply.

## 8. Suspension system

**Note:** Suspension systems for hoists are not treated specifically in this manual. These descriptions are only general information.

- a. The platform can be suspended from different suspension systems such as a roof trolley, a rail, a roof beam, ... .
- b. Suspension systems are calculated to a maximum load of 2.5 times the WLL of the platform. The WLL of each separate hoist can be found on it's nameplate.
- c. For permanent systems that make use of a "roof trolley", check the space between the building and the trolley to make sure there is enough space to move freely.
- d. Make sure the suspension system hangs directly above the platform before commencing with the installation.
- e. For permanent systems that make use of a roof trolley the regulations for installing the rail must be followed.



## Appendix 7: Tuning the Titan overload detection

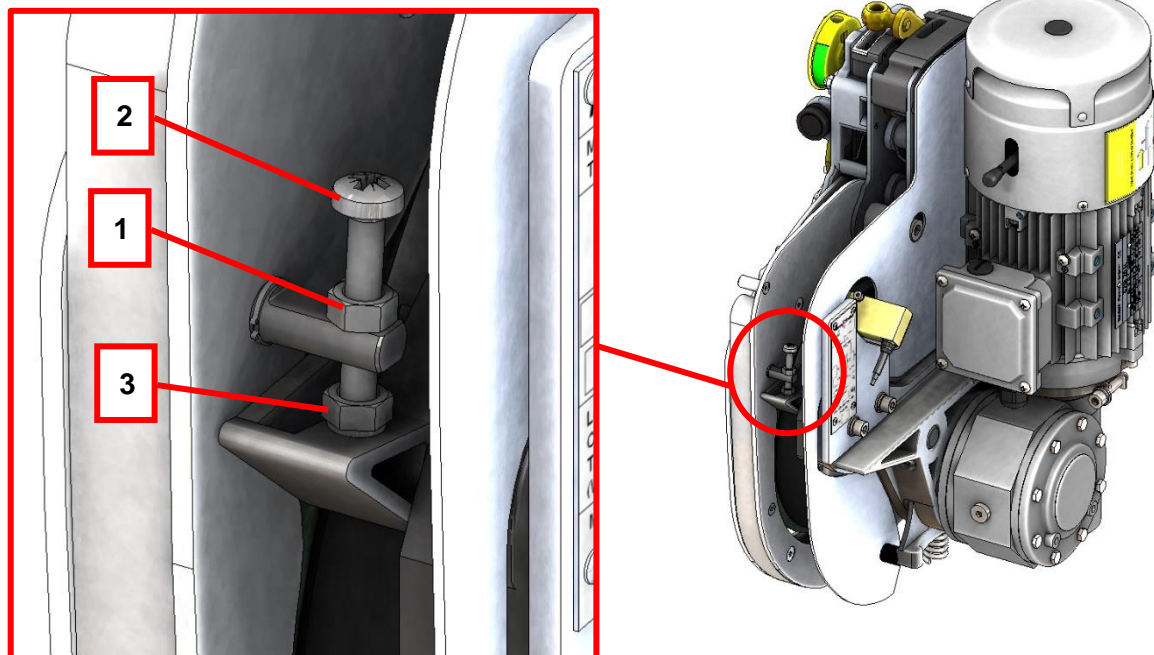

- a. Raise the platform off the ground.
- b. Remove the black front cover (Allen key n°4).
- c. Loosen the lock nut **1**.
- d. Turn the Philips screw **2** clockwise (down) to lower the tripping weight of the overload safety.  
Turn the Philips screw **2** counterclockwise (up) to raise the tripping weight of the overload safety.

The overload is set from factory to trigger at maximally 125% of the rated load, with the rated load distributed over a certain length, determined by the EN1808. Contact Power Climber to check the overload's trip weight for your application.

- e. Lock the screw using the lock nut **1**.

**Tip:** Re-check the overload trip value after locking the screw.

**Important:** Never remove or change the bottom nut's position **3**.

- f. Re-install the front black cover.

## Appendix 8: Troubleshooting

### The platform no longer goes up or down

1. Check if the main switch on the central control panel is ON.
2. Check if the emergency stop on the central control panel has not been activated.
3. Check if the voltage indicator is lit.
4. **Only for 3 phase systems:** Open the central control panel and check if both lights of the phase protection are lit.  
If not, use the following diagram to troubleshoot:

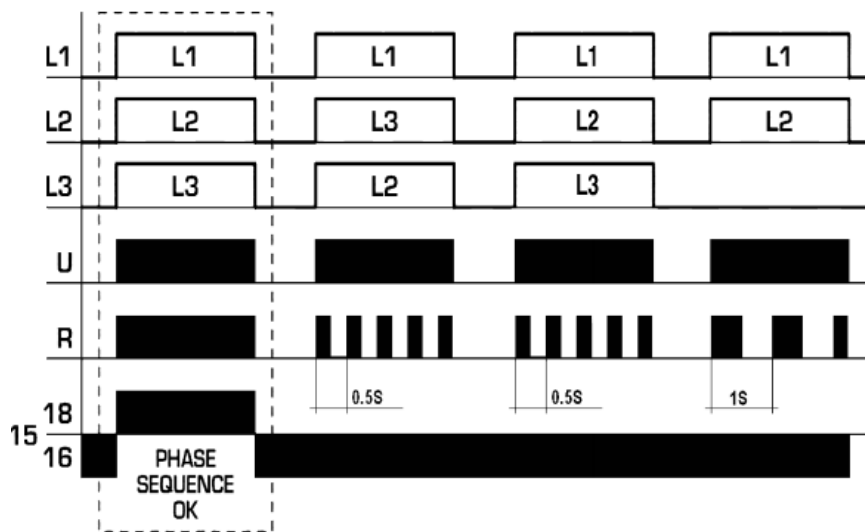

- Red LED is flashing with an interval of 0.5s: wrong phase sequence. Switch over two phases of the power supply.  
**Warning:** Never change a connection in the central control box.
  - Red LED is flashing with an interval of 1: phase failure. Check the power supply.
5. Open the central control panel and check if none of the fuses have blown.
  6. Check if one of the emergency end switches was activated. If a striker plate has activated one of the switches, lower the platform a few cm using the manual brake to deactivate the switches. Inform a supervisor or technician for repair.
  7. Check if none of the hoist's motors is overheating and if the overheat safety has not been activated. When the hoist engine gets overheated, give it time to cool down.  
**Tip:** Lowering with the manual brake will always work, even with an overheated engine.
  8. Check if the red warning light on the central control panel is lit and if the platform could be overloaded. If so, remove the extra weight.

## **The platform goes up, but can't be lowered**

1. Check if the bottom trip bar is not being triggered by an obstacle under the platform.
2. Check if the slack rope safety device has not been activated. The suspension steel wire rope should be tight and the slack rope lever should be in its upright position.
3. Check if the overspeed safety device has not been activated. The yellow reset knob should be in its vertical position.
4. Check if the platform does not slope too much or if the automatic levelling system is active. If so, make sure the hoist selector switch is set to “both hoists” and bring back the platform to the horizontal level.

## **The platform goes down, but can't be pulled up**

1. Check whether none of the top limit switches are being activated.
2. Open the central control panel and check if the thermal relay of one of the wire winders has been activated (these are labelled by “F4L” and “F4R”).

*Tip: The thermal relay may be activated due to overheating. In that case, let the winding drum engines cool down before restarting.*

**If none of the above suggestions solves the issue, contact Power Climber.**

## Appendix 9: Optional controls

### Trolley control

In standard configuration, a separate trolley control box is added to the standard central control box. This extra box will be supplied with (a) plug(s) where the trolley control cable(s) can be plugged in.

#### Single Trolley Control

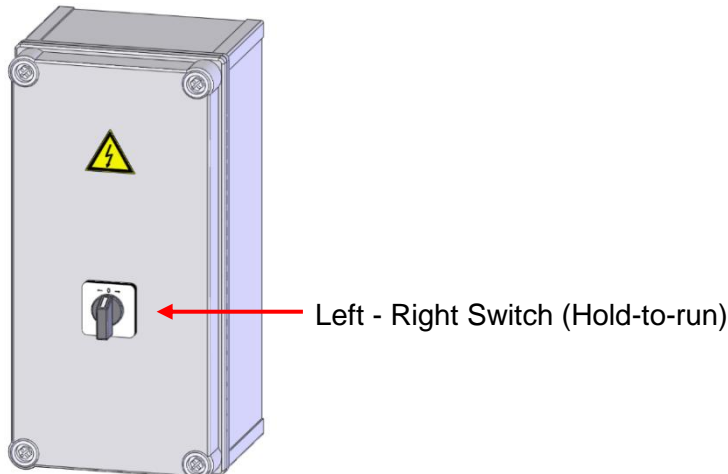

#### Double Trolley Control

Each trolley can be selected and controlled separately

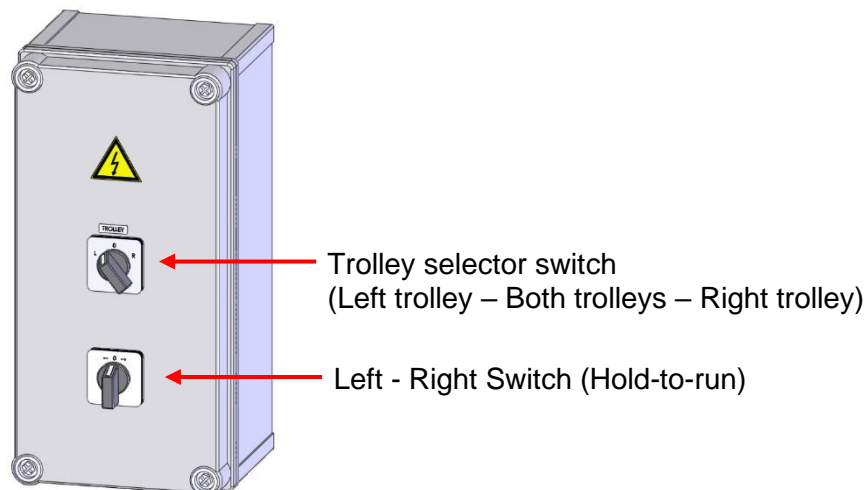

- Connections for trolley “**End Limit Switches**” are foreseen. If none available, these connections need to be bridged to simulate a closed switch.
- **Interlocked** trolley control is available if trolley movement is only wanted in top position. In this case a short trolley control cable is provided. When the cable is plugged in, downward movement of the platform is shut off. To enable the down direction, disconnect the trolley control cable(s).

**PLC - AutoStop**

A platform used in outdoor locations affected by wind, with lifting heights greater than 40m, should be restrained using a restraint system.

To remind the operator(s) that a restraining point is reached, an optional PLC-based ‘AutoStop’ function is available. This function will automatically stop the platform at pre-set heights (usually at the height of each restraining point).

The operator(s) shall then be required to carry out an action to acknowledge that the restraint has been attached/detached from the building, by pushing the bypass button on the central control box. After pushing the bypass button, platform movement is re-enabled.

The standard AutoStop supports up to six stopping heights. Other amount of stops are available (contact Power Climber).

**Display**

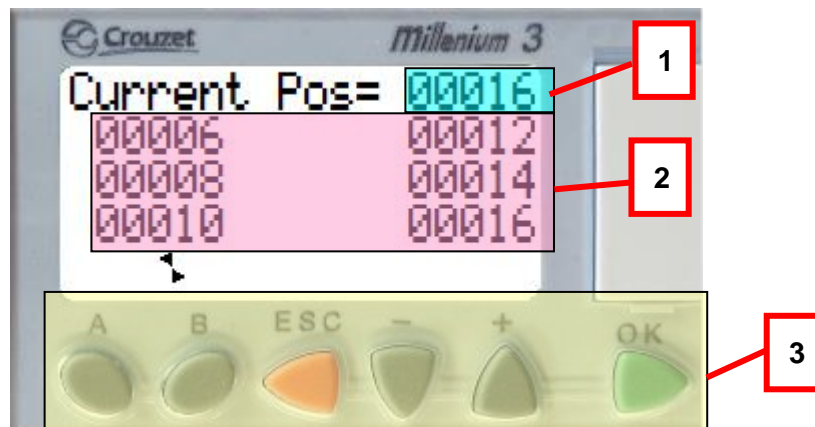

1. Shows the current position of the platform.

**Note:** one unit matches with a height of approx. 150mm.

2. Shows the currently set values of the 6 set restraint levels.
3. Shows the 6 buttons that can be pushed to store and save the 6 restraint levels in the memory of the PLC.  
The correct sequence is from left to right; so button “A” is the first level, button “B” the second level, button “ESC” the third level, etc.

**Note:** The link between the name of a button and the function, normally associated with that name, is non-existent.

### Setting the restraint levels for the first time

- a. After initial installation of the platform (see “Installation”), bring the platform to its top position until it's being stopped by the top limit switches hitting the striker plates. This will initialize the starting position. Verify if the “current position” is set to zero after this initialization.

**Important:** *As the first ascent will be non-restrained in most cases, weather conditions should be taken into account and if needed, precautions should be taken to safely reach the top position.*

**Tip:** *During the first ascent, the platform could reach a random preset level and stop. Push the bypass button to continue the ascent.*

- b. Start to descent and verify if the “current value” changes while moving. When the first restraining point is reached, set the first level by pushing button A. The system will immediately detect this level and thus will disable all movement. Push the bypass button to continue. Repeat for the remaining restraining points by pushing the button which corresponds to the correct level.

- 1<sup>th</sup> level = A
- 2<sup>nd</sup> level = B
- 3<sup>th</sup> level = ESC
- 4<sup>th</sup> level = –
- 5<sup>th</sup> level = +
- 6<sup>th</sup> level = OK

**Note:** *Previously saved position will be overwritten.*

**Tip:** *If less than 6 restraining points are needed, the remaining set values can be set to a value that the platform will never reach during normal operation. Example: keep on operating downward for a while after the platform has landed. The current value will keep on counting and can be used to set the values which won't be used.*

### Calibration

The current position is automatically reset to 0 every time the platform reaches the top limit striker plates.

Make sure that at least one of the top limits are pushed when the platform reaches its top position. This will recalibrate the system.

### Resetting the restraint levels

All restraint levels can be reset to 0 by performing a so-called hard reset, i.e. by pushing both A and B buttons simultaneously for 10 seconds.

## Emergency radio control (Remote control)

The optional radio control only serves as an emergency evacuation, when the user(s) in the platform is no longer able to operate the cage independently.

**Warning:** *Never use the radio control to transport people in circumstances other than an emergency.*

Only downward remote operation is activated with the standard radio control. Optionally, rising can also be activated if it is only possible to evacuate upward. All remaining risks should be considered in a separate risk analysis, taking into account the particular situation and environment the platform is in.

The central control box is fitted with a GREEN “Remote ready” indicator light. It will light up when the remote control is ready for use. It will not light up when:

- a. The receiver is not receiving any voltage (emergency stop pressed, ...)
- b. The emergency stop button on the remote control has been pressed
- c. The remote control is switched off (press green ON button)
- d. The battery of the remote control is empty (charge with supplied charger)

Include the radio control in the daily checklist and test it for proper operation before each use.

**Warning:** *The radio control will override the up and down controls from the work cage itself. The bottom trip bar will be overridden as well, which should be taken into account for the risk analysis and rescue procedure of the entire system.*

*The main safety devices (emergency stop, ultimate top limit switch, overload, motor thermal protection, ...) are never bypassed.*

## **Appendix 10: Splitable Modulo PI**

The optional 'splitable' platform allows the platform to be split into several sections. Assembling the platform using different combinations of these sections result in several configurations of the Modulo PI platform.

**Warning:** *The platform has been designed and set-up to work safely in particular configurations. Assembling the platform in a different configuration or using sections intended for other Modulo PI platforms is strictly prohibited and can result in dangerous situations.*

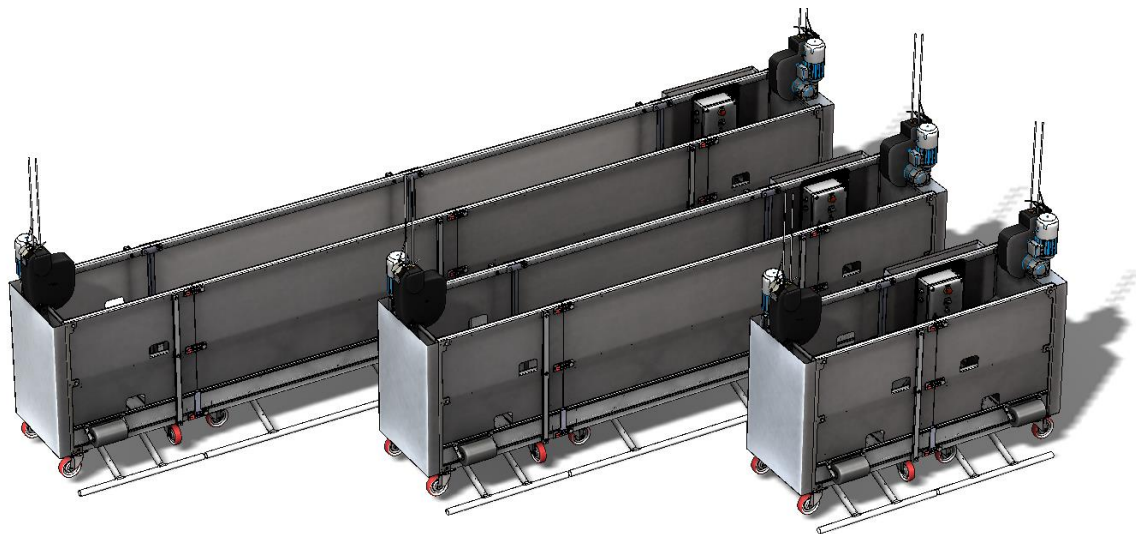

Each section will be marked by a plate with a section letter: **A, B, C, ...**  
Each configuration will have a unique code that is formed using a combination of the section-letters. After assembly, the code must be readable in order from left to right while standing in front of the platform.  
A missing letter or an incorrect code means that the platform has been assembled incorrectly.

All information regarding each configuration can be found on the information plate mounted on the inside of the platform. Read this information carefully before using the platform in that particular configuration.